

MII/RMII 10/100 Ethernet Transceiver with HP Auto-MDIX and flexPWR[®] Technology in a Small Footprint

PRODUCT FEATURES

Datasheet

Highlights

- Single-Chip Ethernet Physical Layer Transceiver (PHY)
- Comprehensive flexPWR[®] Technology
 - Flexible Power Management Architecture
 - Power savings of up to 40% compared to competition
 - LVCMOS Variable I/O voltage range: +1.6V to +3.6V
 - Integrated 1.2V regulator with disable feature
- HP Auto-MDIX support
- Small footprint 32 pin QFN lead-free RoHS compliant package (5 x 5 x 0.9mm height)

Target Applications

- Set-Top Boxes
- Networked Printers and Servers
- Test Instrumentation
- LAN on Motherboard
- Embedded Telecom Applications
- Video Record/Playback Systems
- Cable Modems/Routers
- DSL Modems/Routers
- Digital Video Recorders
- IP and Video Phones
- Wireless Access Points
- Digital Televisions
- Digital Media Adaptors/Servers
- Gaming Consoles
- POE Applications

Key Benefits

- High-Performance 10/100 Ethernet Transceiver
 - Compliant with IEEE802.3/802.3u (Fast Ethernet)
 - Compliant with ISO 802-3/IEEE 802.3 (10BASE-T)
 - Loop-back modes
 - Auto-negotiation
 - Automatic polarity detection and correction
 - Link status change wake-up detection
 - Vendor specific register functions
 - Supports both MII and the reduced pin count RMII interfaces
- Power and I/Os
 - Various low power modes
 - Integrated power-on reset circuit
 - Two status LED outputs
 - Latch-Up Performance Exceeds 150mA per EIA/JESD 78, Class II
 - May be used with a single 3.3V supply
- Packaging
 - 32-pin QFN (5x5 mm) Lead-Free RoHS Compliant package with MII and RMII
- Environmental
 - Extended Commercial Temperature Range (0°C to +85°C)
 - Industrial Temperature Range (-40°C to +85°C) version available (LAN8710i)

ORDER NUMBER(S):

LAN8710A-EZK FOR 32-PIN, QFN LEAD-FREE ROHS COMPLIANT PACKAGE (0 TO +85°C TEMP)
LAN8710Ai-EZK FOR 32-PIN, QFN LEAD-FREE ROHS COMPLIANT PACKAGE (-40 TO +85°C TEMP)
LAN8710A-EZK-TR FOR 32-PIN, QFN LEAD-FREE ROHS COMPLIANT PACKAGE (0 TO +85°C TEMP)
LAN8710Ai-EZK-TR FOR 32-PIN, QFN LEAD-FREE ROHS COMPLIANT PACKAGE (-40 TO +85°C TEMP)

Reel Size is 4000

80 ARKAY DRIVE, HAUPPAUGE, NY 11788 (631) 435-6000, FAX (631) 273-3123

Copyright © 2009 SMSC or its subsidiaries. All rights reserved.

Circuit diagrams and other information relating to SMSC products are included as a means of illustrating typical applications. Consequently, complete information sufficient for construction purposes is not necessarily given. Although the information has been checked and is believed to be accurate, no responsibility is assumed for inaccuracies. SMSC reserves the right to make changes to specifications and product descriptions at any time without notice. Contact your local SMSC sales office to obtain the latest specifications before placing your product order. The provision of this information does not convey to the purchaser of the described semiconductor devices any licenses under any patent rights or other intellectual property rights of SMSC or others. All sales are expressly conditional on your agreement to the terms and conditions of the most recently dated version of SMSC's standard Terms of Sale Agreement dated before the date of your order (the "Terms of Sale Agreement"). The product may contain design defects or errors known as anomalies which may cause the product's functions to deviate from published specifications. Anomaly sheets are available upon request. SMSC products are not designed, intended, authorized or warranted for use in any life support or other application where product failure could cause or contribute to personal injury or severe property damage. Any and all such uses without prior written approval of an Officer of SMSC and further testing and/or modification will be fully at the risk of the customer. Copies of this document or other SMSC literature, as well as the Terms of Sale Agreement, may be obtained by visiting SMSC's website at <http://www.smSC.com>. SMSC is a registered trademark of Standard Microsystems Corporation ("SMSC"). Product names and company names are the trademarks of their respective holders.

SMSC DISCLAIMS AND EXCLUDES ANY AND ALL WARRANTIES, INCLUDING WITHOUT LIMITATION ANY AND ALL IMPLIED WARRANTIES OF MERCHANTABILITY, FITNESS FOR A PARTICULAR PURPOSE, TITLE, AND AGAINST INFRINGEMENT AND THE LIKE, AND ANY AND ALL WARRANTIES ARISING FROM ANY COURSE OF DEALING OR USAGE OF TRADE. IN NO EVENT SHALL SMSC BE LIABLE FOR ANY DIRECT, INCIDENTAL, INDIRECT, SPECIAL, PUNITIVE, OR CONSEQUENTIAL DAMAGES; OR FOR LOST DATA, PROFITS, SAVINGS OR REVENUES OF ANY KIND; REGARDLESS OF THE FORM OF ACTION, WHETHER BASED ON CONTRACT; TORT; NEGLIGENCE OF SMSC OR OTHERS; STRICT LIABILITY; BREACH OF WARRANTY; OR OTHERWISE; WHETHER OR NOT ANY REMEDY OF BUYER IS HELD TO HAVE FAILED OF ITS ESSENTIAL PURPOSE, AND WHETHER OR NOT SMSC HAS BEEN ADVISED OF THE POSSIBILITY OF SUCH DAMAGES.

Table of Contents

Chapter 1 Introduction	9
1.1 General Terms and Conventions	9
1.2 General Description	9
1.3 Architectural Overview	10
1.3.1 Configuration	10
Chapter 2 Pin Configuration	12
2.1 Package Pin-out Diagram and Signal Table	12
Chapter 3 Pin Description	14
3.1 MAC Interface Signals	14
3.2 LED Signals	16
3.3 Management Signals	17
3.4 General Signals	17
3.5 10/100 Line Interface Signals	17
3.6 Analog Reference	18
3.7 Power Signals	18
Chapter 4 Architecture Details	19
4.1 Top Level Functional Architecture	19
4.2 100Base-TX Transmit	19
4.2.1 100M Transmit Data Across the MII/RMII Interface	19
4.2.2 4B/5B Encoding	20
4.2.3 Scrambling	21
4.2.4 NRZI and MLT3 Encoding	21
4.2.5 100M Transmit Driver	21
4.2.6 100M Phase Lock Loop (PLL)	22
4.3 100Base-TX Receive	22
4.3.1 100M Receive Input	22
4.3.2 Equalizer, Baseline Wander Correction and Clock and Data Recovery	22
4.3.3 NRZI and MLT-3 Decoding	23
4.3.4 Descrambling	23
4.3.5 Alignment	23
4.3.6 5B/4B Decoding	23
4.3.7 Receive Data Valid Signal	23
4.3.8 Receiver Errors	24
4.3.9 100M Receive Data Across the MII/RMII Interface	24
4.4 10Base-T Transmit	24
4.4.1 10M Transmit Data Across the MII/RMII Interface	24
4.4.2 Manchester Encoding	25
4.4.3 10M Transmit Drivers	25
4.5 10Base-T Receive	25
4.5.1 10M Receive Input and Squelch	25
4.5.2 Manchester Decoding	25
4.5.3 10M Receive Data Across the MII/RMII Interface	26
4.5.4 Jabber Detection	26
4.6 MAC Interface	26
4.6.1 MII	26
4.6.2 RMII	26
4.6.3 MII vs. RMII Configuration	27
4.7 Auto-negotiation	28

4.7.1	Parallel Detection	30
4.7.2	Re-starting Auto-negotiation	30
4.7.3	Disabling Auto-negotiation	30
4.7.4	Half vs. Full Duplex	30
4.8	HP Auto-MDIX Support	30
4.9	Internal +1.2V Regulator Disable	31
4.9.1	Disable the Internal +1.2V Regulator	31
4.9.2	Enable the Internal +1.2V Regulator	31
4.10	nINTSEL Strapping and LED Polarity Selection	32
4.11	REGOFF and LED Polarity Selection	32
4.12	PHY Address Strapping	33
4.13	Variable Voltage I/O	33
4.14	Transceiver Management Control	33
4.14.1	Serial Management Interface (SMI)	33

Chapter 5 SMI Register Mapping **35**

5.1	SMI Register Format	39
5.2	Interrupt Management	47
5.2.1	Primary Interrupt System	47
5.2.2	Alternate Interrupt System	48
5.3	Miscellaneous Functions	48
5.3.1	Carrier Sense	48
5.3.2	Collision Detect	49
5.3.3	Isolate Mode	49
5.3.4	Link Integrity Test	49
5.3.5	Power-Down modes	49
5.3.6	Reset	50
5.3.7	LED Description	50
5.3.8	Loopback Operation	50
5.3.9	Configuration Signals	52

Chapter 6 AC Electrical Characteristics **55**

6.1	Serial Management Interface (SMI) Timing	55
6.2	MII 10/100Base-TX/RX Timings	56
6.2.1	MII 100Base-T TX/RX Timings	56
6.2.2	MII 10Base-T TX/RX Timings	58
6.3	RMII 10/100Base-TX/RX Timings (50MHz REF_CLK IN)	60
6.3.1	RMII 100Base-T TX/RX Timings (50MHz REF_CLK IN)	60
6.3.2	RMII 10Base-T TX/RX Timings (50MHz REF_CLK IN)	62
6.4	RMII CLKIN Requirements	64
6.5	Reset Timing	64
6.6	Clock Circuit	65

Chapter 7 DC Electrical Characteristics **66**

7.1	DC Characteristics	66
7.1.1	Maximum Guaranteed Ratings	66
7.1.2	Operating Conditions	67
7.1.3	Power Consumption	68
7.1.4	DC Characteristics - Input and Output Buffers	69

Chapter 8 Application Notes **73**

8.1	Application Diagram	73
8.1.1	MII Diagram	73
8.1.2	Power Supply Diagram	74



Datasheet

8.1.3	Twisted-Pair Interface Diagram	74
8.2	Magnetics Selection	75
<hr/>		
Chapter 9	Package Outline	76

List of Figures

Figure 1.1	LAN8710/LAN8710i System Block Diagram	10
Figure 1.2	LAN8710/LAN8710i Architectural Overview	11
Figure 2.1	LAN8710/LAN8710i 32-QFN Pin Assignments (TOP VIEW)	12
Figure 4.1	100Base-TX Data Path	19
Figure 4.2	Receive Data Path	22
Figure 4.3	Relationship Between Received Data and Specific MII Signals	24
Figure 4.4	Direct Cable Connection vs. Cross-over Cable Connection	31
Figure 4.5	nINTSEL Strapping on LED2	32
Figure 4.6	REGOFF Configuration on LED1	33
Figure 4.7	MDIO Timing and Frame Structure - READ Cycle	34
Figure 4.8	MDIO Timing and Frame Structure - WRITE Cycle	34
Figure 5.1	Near-end Loopback Block Diagram	51
Figure 5.2	Far Loopback Block Diagram	51
Figure 5.3	Connector Loopback Block Diagram	52
Figure 6.1	SMI Timing Diagram	55
Figure 6.2	100M MII Receive Timing Diagram	56
Figure 6.3	100M MII Transmit Timing Diagram	57
Figure 6.4	10M MII Receive Timing Diagram	58
Figure 6.5	10M MII Transmit Timing Diagrams	59
Figure 6.6	100M RMII Receive Timing Diagram (50MHz REF_CLK IN)	60
Figure 6.7	100M RMII Transmit Timing Diagram (50MHz REF_CLK IN)	61
Figure 6.8	10M RMII Receive Timing Diagram (50MHz REF_CLK IN)	62
Figure 6.9	10M RMII Transmit Timing Diagram (50MHz REF_CLK IN)	63
Figure 6.10	Reset Timing Diagram	64
Figure 8.1	Simplified Application Diagram	73
Figure 8.2	High-Level System Diagram for Power	74
Figure 8.3	High-Level System Diagram for Power	74
Figure 8.4	Copper Interface Diagram	74
Figure 8.5	Copper Interface Diagram	74
Figure 9.1	LAN8710/LAN8710i-EZK 32 Pin QFN Package Outline, 5 x 5 x 0.9 mm Body (Lead-Free)	76
Figure 9.1	QFN, 5x5 Taping Dimensions and Part Orientation	77
Figure 9.2	Reel Dimensions for 12mm Carrier Tape	78
Figure 9.3	Tape Length and Part Quantity	79

Datasheet

List of Tables

Table 2.1	LAN8710/LAN8710i 32-PIN QFN Pinout	13
Table 3.1	Buffer Types	14
Table 3.2	MII/RMII Signals 32-QFN	14
Table 3.3	LED Signals 32-QFN	16
Table 3.4	Management Signals 32-QFN	17
Table 3.5	General Signals 32-QFN	17
Table 3.6	10/100 Line Interface Signals 32-QFN	17
Table 3.7	Analog References 32-QFN	18
Table 3.8	Power Signals 32-QFN	18
Table 4.1	4B/5B Code Table	20
Table 4.2	MII/RMII Signal Mapping	28
Table 4.3	Configuration	32
Table 5.1	Control Register: Register 0 (Basic)	35
Table 5.2	Status Register: Register 1 (Basic)	35
Table 5.3	PHY ID 1 Register: Register 2 (Extended)	35
Table 5.4	PHY ID 2 Register: Register 3 (Extended)	35
Table 5.5	Auto-Negotiation Advertisement: Register 4 (Extended)	36
Table 5.6	Auto-Negotiation Link Partner Base Page Ability Register: Register 5 (Extended)	36
Table 5.7	Auto-Negotiation Expansion Register: Register 6 (Extended)	36
Table 5.8	Register 15 (Extended)	36
Table 5.9	Silicon Revision Register 16: Vendor-Specific	36
Table 5.10	Mode Control/ Status Register 17: Vendor-Specific	37
Table 5.11	Special Modes Register 18: Vendor-Specific	37
Table 5.12	Register 24: Vendor-Specific	37
Table 5.13	Register 25: Vendor-Specific	37
Table 5.14	Symbol Error Counter Register 26: Vendor-Specific	37
Table 5.15	Special Control/Status Indications Register 27: Vendor-Specific	38
Table 5.16	Special Internal Testability Control Register 28: Vendor-Specific	38
Table 5.17	Interrupt Source Flags Register 29: Vendor-Specific	38
Table 5.18	Interrupt Mask Register 30: Vendor-Specific	38
Table 5.19	PHY Special Control/Status Register 31: Vendor-Specific	38
Table 5.20	SMI Register Mapping	39
Table 5.21	Register 0 - Basic Control	40
Table 5.22	Register 1 - Basic Status	40
Table 5.23	Register 2 - PHY Identifier 1	41
Table 5.24	Register 3 - PHY Identifier 2	41
Table 5.25	Register 4 - Auto Negotiation Advertisement	41
Table 5.26	Register 5 - Auto Negotiation Link Partner Ability	42
Table 5.27	Register 6 - Auto Negotiation Expansion	43
Table 5.28	Register 16 - Silicon Revision	43
Table 5.29	Register 17 - Mode Control/Status	43
Table 5.30	Register 18 - Special Modes	44
Table 5.31	Register 26 - Symbol Error Counter	44
Table 5.33	Register 28 - Special Internal Testability Controls	45
Table 5.34	Register 29 - Interrupt Source Flags	45
Table 5.32	Register 27 - Special Control/Status Indications	45
Table 5.35	Register 30 - Interrupt Mask	46
Table 5.36	Register 31 - PHY Special Control/Status	46
Table 5.37	Interrupt Management Table	47
Table 5.38	Alternative Interrupt System Management Table	48
Table 5.39	Pin Names for Address Bits	52
Table 5.40	MODE[2:0] Bus	53
Table 5.41	Pin Names for Mode Bits	53

Table 6.1	SMI Timing Values	55
Table 6.2	100M MII Receive Timing Values	56
Table 6.3	100M MII Transmit Timing Values	57
Table 6.4	10M MII Receive Timing Values	58
Table 6.5	10M MII Transmit Timing Values	59
Table 6.6	100M RMII Receive Timing Values (50MHz REF_CLK IN)	60
Table 6.7	100M RMII Transmit Timing Values (50MHz REF_CLK IN)	61
Table 6.8	10M RMII Receive Timing Values (50MHz REF_CLK IN)	62
Table 6.9	10M RMII Transmit Timing Values (50MHz REF_CLK IN)	63
Table 6.10	RMII CLKIN (REF_CLK) Timing Values	64
Table 6.11	Reset Timing Values	64
Table 6.12	LAN8710/LAN8710i Crystal Specifications	65
Table 7.1	Maximum Conditions	66
Table 7.2	ESD and LATCH-UP Performance	66
Table 7.3	Recommended Operating Conditions	67
Table 7.4	Power Consumption Device Only	68
Table 7.5	MII Bus Interface Signals	69
Table 7.6	LAN Interface Signals	70
Table 7.7	LED Signals	70
Table 7.8	Configuration Inputs	70
Table 7.9	General Signals	70
Table 7.10	Internal Pull-Up / Pull-Down Configurations	71
Table 7.11	100Base-TX Transceiver Characteristics	71
Table 7.12	10BASE-T Transceiver Characteristics	72
Table 9.1	32 Terminal QFN Package Parameters	76

Chapter 1 Introduction

1.1 General Terms and Conventions

The following is list of the general terms used in this document:

BYTE	8-bits
FIFO	First In First Out buffer; often used for elasticity buffer
MAC	Media Access Controller
MII	Media Independent Interface
RMII™	Reduced Media Independent Interface™
N/A	Not Applicable
X	Indicates that a logic state is “don’t care” or undefined.
RESERVED	Refers to a reserved bit field or address. Unless otherwise noted, reserved bits must always be zero for write operations. Unless otherwise noted, values are not guaranteed when reading reserved bits. Unless otherwise noted, do not read or write to reserved addresses.
SMI	Serial Management Interface

1.2 General Description

The LAN8710/LAN8710i is a low-power 10BASE-T/100BASE-TX physical layer (PHY) transceiver that transmits and receives on unshielded twisted-pair cable. A typical system application is shown in [Figure 1.2](#). It is available in both extended commercial and industrial temperature operating versions.

The LAN8710/LAN8710i interfaces to the MAC layer using a variable voltage digital interface via the standard MII (IEEE 802.3u). Support for RMII makes a reduced pin-count interface available. The digital interface pins are tolerant to 3.6V.

The LAN8710/LAN8710i implements Auto-Negotiation to automatically determine the best possible speed and duplex mode of operation. HP Auto-MDIX support allows using a direct connect LAN cable, or a cross-over path cable.

The LAN8710 referenced throughout this document applies to both the extended commercial temperature and industrial temperature components. The LAN8710i refers to only the industrial temperature component.

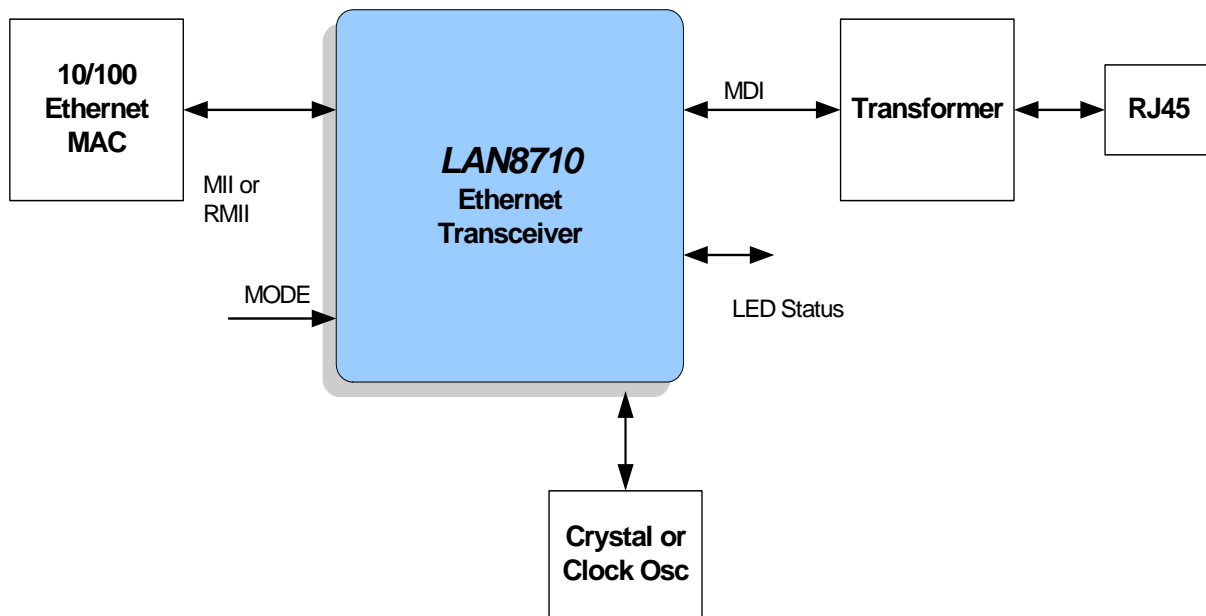

Figure 1.1 LAN8710/LAN8710i System Block Diagram

1.3 Architectural Overview

The LAN8710/LAN8710i is compliant with IEEE 802.3-2005 standards (MII Pins tolerant to 3.6V) and supports both IEEE 802.3-2005 compliant and vendor-specific register functions. It contains a full-duplex 10-BASE-T/100BASE-TX transceiver and supports 10-Mbps (10BASE-T) operation, and 100-Mbps (100BASE-TX) operation. The LAN8710/LAN8710i can be configured to operate on a single 3.3V supply utilizing an integrated 3.3V to 1.2V linear regulator. An option is available to disable the linear regulator to optimize system designs that have a 1.2V power supply available. This allows for the use of a high efficiency external regulator for lower system power dissipation.

1.3.1 Configuration

The LAN8710 will begin normal operation following reset, and no register access is required. The initial configuration may be selected with configuration pins as described in [Section 5.3.9](#). In addition, register-selectable configuration options may be used to further define the functionality of the transceiver. For example, the device can be set to 10BASE-T only. The LAN8710 supports both IEEE 802.3-2005 compliant and vendor-specific register functions.

Datasheet

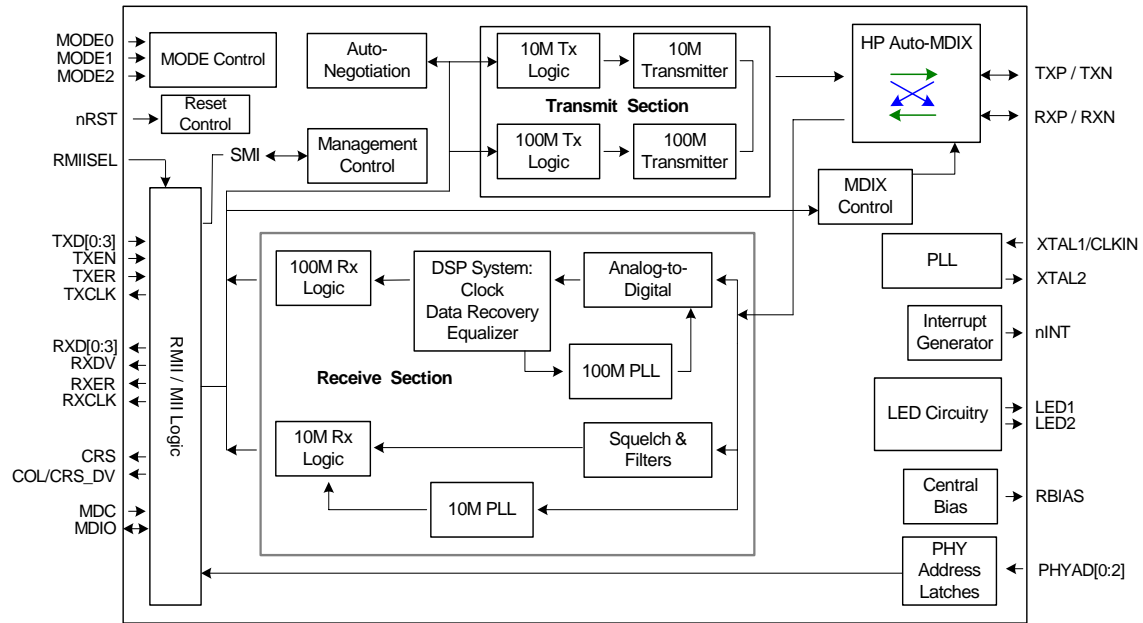

Figure 1.2 LAN8710/LAN8710i Architectural Overview

Chapter 2 Pin Configuration

2.1 Package Pin-out Diagram and Signal Table

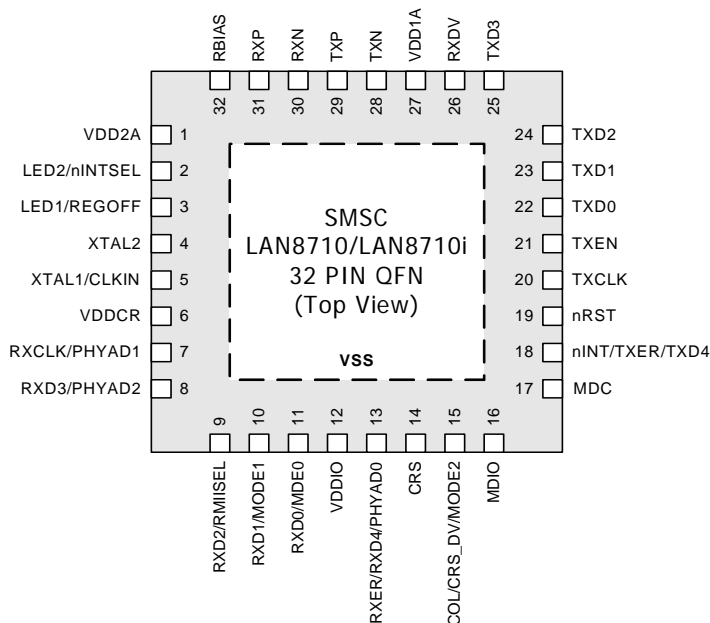

Figure 2.1 LAN8710/LAN8710i 32-QFN Pin Assignments (TOP VIEW)



Datasheet

Table 2.1 LAN8710/LAN8710i 32-PIN QFN Pinout

PIN NO.	PIN NAME	PIN NO.	PIN NAME
1	VDD2A	17	MDC
2	LED2/nINTSEL	18	nINT/TXER/TXD4
3	LED1/REGOFF	19	nRST
4	XTAL2	20	TXCLK
5	XTAL1/CLKIN	21	TXEN
6	VDDCR	22	TXD0
7	RXCLK//PHYAD1	23	TXD1
8	RXD3/PHYAD2	24	TXD2
9	RXD2/RMIISEL	25	TXD3
10	RXD1/MODE1	26	RXDV
11	RXD0/MODE0	27	VDD1A
12	VDDIO	28	TXN
13	RXER/RXD4/PHYAD0	29	TXP
14	CRS	30	RXN
15	COL/CRS_DV/MODE2	31	RXP
16	MDIO	32	RBIAS

Chapter 3 Pin Description

This chapter describes the signals on each pin. When a lower case “n” is used at the beginning of the signal name, it indicates that the signal is active low. For example, nRST indicates that the reset signal is active low. The buffer type for each signal is indicated in the TYPE column, and a description of the buffer types is provided in [Table 3.1](#).

Table 3.1 Buffer Types

BUFFER TYPE	DESCRIPTION
I8	Input.
O8	Output with 8mA sink and 8mA source.
IOD8	Input/Open-drain output with 8mA sink.
IPU Note 3.1	Input with 67k (typical) internal pull-up.
IPD Note 3.1	Input with 67k (typical) internal pull-down.
IOPU Note 3.1	Input/Output with 67k (typical) internal pull-up. Output has 8mA sink and 8mA source.
IOPD Note 3.1	Input/Output with 67k (typical) internal pull-down. Output has 8mA sink and 8mA source.
AI	Analog input
AIO	Analog bi-directional
ICLK	Crystal oscillator input pin
OCLK	Crystal oscillator output pin
P	Power pin

Note 3.1 Unless otherwise noted in the pin description, internal pull-up and pull-down resistors are always enabled. The internal pull-up and pull-down resistors prevent unconnected inputs from floating, and must not be relied upon to drive signals external to LAN8710/LAN8710i. When connected to a load that must be pulled high or low, an external resistor must be added.

Note: The digital signals are not 5V tolerant. They are variable voltage from +1.6V to +3.6V, as shown in [Table 7.1](#).

3.1 MAC Interface Signals

Table 3.2 MII/RMII Signals 32-QFN

SIGNAL NAME	32-QFN PIN #	TYPE	DESCRIPTION
TXD0	22	I8	Transmit Data 0: The MAC transmits data to the transceiver using this signal in all modes.
TXD1	23	I8	Transmit Data 1: The MAC transmits data to the transceiver using this signal in all modes

Table 3.2 MII/RMII Signals (continued) 32-QFN (continued)

SIGNAL NAME	32-QFN PIN #	TYPE	DESCRIPTION
TXD2	24	I8	<p>Transmit Data 2: The MAC transmits data to the transceiver using this signal in MII Mode.</p> <ul style="list-style-type: none"> This signal should be grounded in RMII Mode.
TXD3	25	I8	<p>Transmit Data 3: The MAC transmits data to the transceiver using this signal in MII Mode.</p> <ul style="list-style-type: none"> This signal should be grounded in RMII Mode.
nINT/ TXER/ TXD4	18	IOPU	<p>nINT – Active low interrupt output. Place an external resistor pull-up to VDDIO.</p> <ul style="list-style-type: none"> See Section 4.10 for information on how nINTSEL is used to determine the function for this pin. <p>TXER – MII Transmit Error: When driven high, the 4B/5B encode process substitutes the Transmit Error code-group (/H/) for the encoded data word. This input is ignored in 10Base-T operation.</p> <p>TXD4 – MII Transmit Data 4: In Symbol Interface (5B Decoding) mode, this signal becomes the MII Transmit Data 4 line, the MSB of the 5-bit symbol code-group.</p> <ul style="list-style-type: none"> TXD4 is not used in RMII Mode. This signal is mux'd with nINT
TXEN	21	IPD	<p>Transmit Enable: Indicates that valid data is presented on the TXD[3:0] signals, for transmission. In RMII Mode, only TXD[1:0] have valid data.</p>
TXCLK	20	O8	<p>Transmit Clock: Used to latch data from the MAC into the transceiver.</p> <ul style="list-style-type: none"> MII (100BT): 25MHz MII (10BT): 2.5MHz This signal is not used in RMII Mode.
RXD0/ MODE0	11	IOPU	<p>RXD0 – Receive Data 0: Bit 0 of the 4 data bits that are sent by the transceiver in the receive path.</p> <p>MODE0 – PHY Operating Mode Bit 0: set the default MODE of the PHY.</p> <ul style="list-style-type: none"> See Section 5.3.9.2 for information on the MODE options.
RXD1/ MODE1	10	IOPU	<p>RXD1 – Receive Data 1: Bit 1 of the 4 data bits that are sent by the PHY in the receive path.</p> <p>MODE1 – PHY Operating Mode Bit 1: set the default MODE of the PHY.</p> <ul style="list-style-type: none"> See Section 5.3.9.2 for information on the MODE options.
RXD2/ RMIISEL	9	IOPD	<p>RXD2 – Receive Data 2: Bit 2 of the 4 data bits that are sent by the transceiver in the receive path.</p> <ul style="list-style-type: none"> The RXD2 signal is not used in RMII Mode. <p>RMIISEL – MII/RMII Mode Selection: Latched on the rising edge of the internal reset (nRESET) based on the following strapping:</p> <ul style="list-style-type: none"> By default, MII mode is selected. Pull this pin high to VDDIO with an external resistor to select RMII mode,
RXD3/ PHYAD2	8	IOPD	<p>RXD3 – Receive Data 3: Bit 3 of the 4 data bits that are sent by the transceiver in the receive path.</p> <ul style="list-style-type: none"> This signal is not used in RMII Mode. This signal is mux'd with PHYAD2 <p>PHYAD2 – PHY Address Bit 2: set the SMI address of the transceiver.</p> <ul style="list-style-type: none"> See Section 5.3.9.1 for information on the ADDRESS options.

Table 3.2 MII/RMII Signals (continued) 32-QFN (continued)

SIGNAL NAME	32-QFN PIN #	TYPE	DESCRIPTION
RXER/ RXD4/ PHYAD0	13	IOPD	<p>RXER – Receive Error: Asserted to indicate that an error was detected somewhere in the frame presently being transferred from the transceiver.</p> <ul style="list-style-type: none"> ■ The RXER signal is optional in RMII Mode. <p>RXD4 – MII Receive Data 4: In Symbol Interface (5B Decoding) mode, this signal is the MII Receive Data 4 signal, the MSB of the received 5-bit symbol code-group. Unless configured in this mode, the pin functions as RXER.</p> <ul style="list-style-type: none"> ■ This signal is mux'd with PHYAD0 <p>PHYAD0 – PHY Address Bit 0: set the SMI address of the PHY.</p> <ul style="list-style-type: none"> ■ See Section 5.3.9.1 for information on the ADDRESS options.
RXCLK/ PHYAD1	7	IOPD	<p>RXCLK – Receive Clock: In MII mode, this pin is the receive clock output. 25MHz in 100Base-TX mode. 2.5MHz in 10Base-T mode.</p> <ul style="list-style-type: none"> ■ This signal is mux'd with PHYAD1 <p>PHYAD1 – PHY Address Bit 1: set the SMI address of the transceiver.</p> <ul style="list-style-type: none"> ■ See Section 5.3.9.1 for information on the ADDRESS options.
RXDV	26	O8	<p>Receive Data Valid: Indicates that recovered and decoded data is being presented on RXD pins.</p>
COL/ CRS_DV/ MODE2	15	IOPU	<p>COL – MII Mode Collision Detect: Asserted to indicate detection of collision condition.</p> <p>CRS_DV – RMII Mode CRS_DV (Carrier Sense/Receive Data Valid) Asserted to indicate when the receive medium is non-idle. When a 10BT packet is received, CRS_DV is asserted, but RXD[1:0] is held low until the SFD byte (10101011) is received. In 10BT, half-duplex mode, transmitted data is not looped back onto the receive data pins, per the RMII standard.</p> <p>MODE2 – PHY Operating Mode Bit 2: set the default MODE of the PHY.</p> <ul style="list-style-type: none"> ■ See Section 5.3.9.2 for information on the MODE options.
CRS	14	IOPD	<p>Carrier Sense: Indicates detection of carrier.</p>

3.2 LED Signals

Table 3.3 LED Signals 32-QFN

SIGNAL NAME	32-QFN PIN #	TYPE	DESCRIPTION
LED1/ REGOFF	3	IOPD	<p>LED1 – Link activity LED Indication. See Section 5.3.7 for a description of LED modes.</p> <p>REGOFF – Regulator Off: This pin may be used to configure the internal 1.2V regulator off. As described in Section 4.9, this pin is sampled during the power-on sequence to determine if the internal regulator should turn on. When the regulator is disabled, external 1.2V must be supplied to VDDCR.</p> <ul style="list-style-type: none"> ■ When LED1/REGOFF is pulled high to VDD2A with an external resistor, the internal regulator is disabled. ■ When LED1/REGOFF is floating or pulled low, the internal regulator is enabled (default).

Table 3.3 LED Signals 32-QFN (continued)

SIGNAL NAME	32-QFN PIN #	TYPE	DESCRIPTION
LED2/ nINTSEL	2	IOPU	<p>LED2 – Link Speed LED Indication. See Section 5.3.7 for a description of LED modes.</p> <p>nINTSEL: On power-up or external reset, the mode of the nINT/TXER/TXD4 pin is selected.</p> <ul style="list-style-type: none"> ■ When LED2/nINTSEL is floated or pulled to VDDIO, nINT is selected for operation on pin nINT/TXER/TXD4 (default). ■ When LED2/nINTSEL is pulled low to VSS through a resistor, TXER/TXD4 is selected for operation on pin nINT/TXER/TXD4. ■ See Section 4.10 for additional information.

3.3 Management Signals

Table 3.4 Management Signals 32-QFN

SIGNAL NAME	32-QFN PIN #	TYPE	DESCRIPTION
MDIO	16	IOD8	Management Data Input/OUTPUT : Serial management data input/output.
MDC	17	I8	Management Clock : Serial management clock.

3.4 General Signals

Table 3.5 General Signals 32-QFN

SIGNAL NAME	32-QFN PIN #	TYPE	DESCRIPTION
XTAL1/ CLKIN	5	ICLK	Clock Input : Crystal connection or external clock input.
XTAL2	4	OCLK	Clock Output : Crystal connection. Float this pin when an external clock is driven to XTAL1/CLKIN.
nRST	19	IOPU	External Reset : Input of the system reset. This signal is active LOW.

3.5 10/100 Line Interface Signals

Table 3.6 10/100 Line Interface Signals 32-QFN

SIGNAL NAME	32-QFN PIN #	TYPE	DESCRIPTION
TXP	29	AIO	Transmit/Receive Positive Channel 1 .

Table 3.6 10/100 Line Interface Signals (continued) 32-QFN (continued)

SIGNAL NAME	32-QFN PIN #	TYPE	DESCRIPTION
TXN	28	AIO	Transmit/Receive Negative Channel 1.
RXP	31	AIO	Transmit/Receive Positive Channel 2.
RXN	30	AIO	Transmit/Receive Negative Channel 2.

3.6 Analog Reference

Table 3.7 Analog References 32-QFN

SIGNAL NAME	32-QFN PIN #	TYPE	DESCRIPTION
RBIAS	32	AI	External 1% Bias Resistor. Requires a 12.1k ohm (1%) resistor to ground connected as described in the Analog Layout Guidelines. The nominal voltage is 1.2V and the resistor will dissipate approximately 1mW of power.

3.7 Power Signals

Table 3.8 Power Signals 32-QFN

SIGNAL NAME	32-QFN PIN #	TYPE	DESCRIPTION
VDDIO	12	P	+1.6V to +3.6V Variable I/O Pad Power
VDDCR	6	P	+1.2V (Core voltage) - 1.2V for digital circuitry on chip. Supplied by the on-chip regulator unless configured for regulator off mode using the LED1/REGOFF pin. A 1uF decoupling capacitor to ground should be used on this pin when using the internal 1.2V regulator.
VDD1A	27	P	+3.3V Analog Port Power to Channel 1.
VDD2A	1	P	+3.3V Analog Port Power to Channel 2 and to internal regulator.
VSS	FLAG	GND	The flag must be connected to the ground plane with a via array under the exposed flag. This is the ground connection for the IC.

Chapter 4 Architecture Details

4.1 Top Level Functional Architecture

Functionally, the transceiver can be divided into the following sections:

- 100Base-TX transmit and receive
- 10Base-T transmit and receive
- MII or RMII interface to the controller
- Auto-negotiation to automatically determine the best speed and duplex possible
- Management Control to read status registers and write control registers

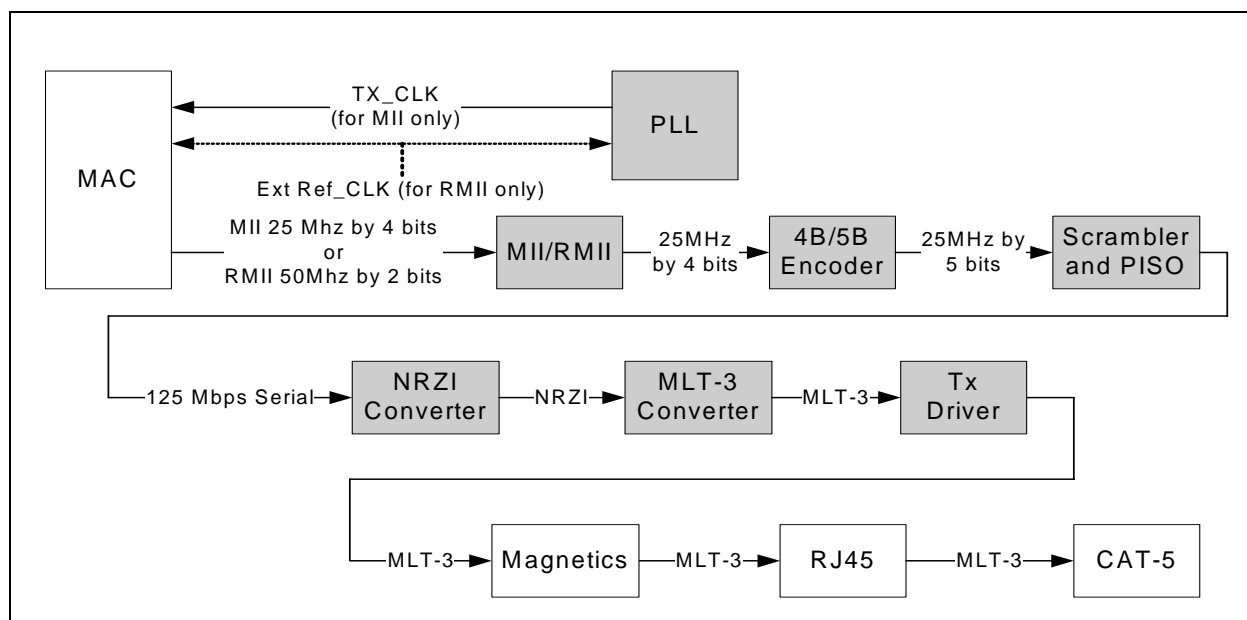

Figure 4.1 100Base-TX Data Path

4.2 100Base-TX Transmit

The data path of the 100Base-TX is shown in [Figure 4.1](#). Each major block is explained below.

4.2.1 100M Transmit Data Across the MII/RMII Interface

For MII, the MAC controller drives the transmit data onto the TXD bus and asserts TXEN to indicate valid data. The data is latched by the transceiver's MII block on the rising edge of TXCLK. The data is in the form of 4-bit wide 25MHz data.

For RMII, the MAC controller drives the transmit data onto the TXD bus and asserts TXEN to indicate valid data. The data is latched by the transceiver's RMII block on the rising edge of REF_CLK. The data is in the form of 2-bit wide 50MHz data.

4.2.2 4B/5B Encoding

The transmit data passes from the MII block to the 4B/5B encoder. This block encodes the data from 4-bit nibbles to 5-bit symbols (known as “code-groups”) according to Table 4.1. Each 4-bit data-nibble is mapped to 16 of the 32 possible code-groups. The remaining 16 code-groups are either used for control information or are not valid.

The first 16 code-groups are referred to by the hexadecimal values of their corresponding data nibbles, 0 through F. The remaining code-groups are given letter designations with slashes on either side. For example, an IDLE code-group is /I/, a transmit error code-group is /H/, etc.

The encoding process may be bypassed by clearing bit 6 of register 31. When the encoding is bypassed the 5th transmit data bit is equivalent to TXER.

Note that encoding can be bypassed only when the MAC interface is configured to operate in MII mode.

Table 4.1 4B/5B Code Table

CODE GROUP	SYM	RECEIVER INTERPRETATION			TRANSMITTER INTERPRETATION		
11110	0	0	0000	DATA	0	0000	DATA
01001	1	1	0001		1	0001	
10100	2	2	0010		2	0010	
10101	3	3	0011		3	0011	
01010	4	4	0100		4	0100	
01011	5	5	0101		5	0101	
01110	6	6	0110		6	0110	
01111	7	7	0111		7	0111	
10010	8	8	1000		8	1000	
10011	9	9	1001		9	1001	
10110	A	A	1010		A	1010	
10111	B	B	1011		B	1011	
11010	C	C	1100		C	1100	
11011	D	D	1101		D	1101	
11100	E	E	1110		E	1110	
11101	F	F	1111		F	1111	
11111	I	IDLE			Sent after /T/R until TXEN		
11000	J	First nibble of SSD, translated to “0101” following IDLE, else RXER			Sent for rising TXEN		
10001	K	Second nibble of SSD, translated to “0101” following J, else RXER			Sent for rising TXEN		
01101	T	First nibble of ESD, causes de-assertion of CRS if followed by /R/, else assertion of RXER			Sent for falling TXEN		

Table 4.1 4B/5B Code Table (continued)

CODE GROUP	SYM	RECEIVER INTERPRETATION	TRANSMITTER INTERPRETATION
00111	R	Second nibble of ESD, causes deassertion of CRS if following /T/, else assertion of RXER	Sent for falling TXEN
00100	H	Transmit Error Symbol	Sent for rising TXER
00110	V	INVALID, RXER if during RXDV	INVALID
11001	V	INVALID, RXER if during RXDV	INVALID
00000	V	INVALID, RXER if during RXDV	INVALID
00001	V	INVALID, RXER if during RXDV	INVALID
00010	V	INVALID, RXER if during RXDV	INVALID
00011	V	INVALID, RXER if during RXDV	INVALID
00101	V	INVALID, RXER if during RXDV	INVALID
01000	V	INVALID, RXER if during RXDV	INVALID
01100	V	INVALID, RXER if during RXDV	INVALID
10000	V	INVALID, RXER if during RXDV	INVALID

4.2.3 Scrambling

Repeated data patterns (especially the IDLE code-group) can have power spectral densities with large narrow-band peaks. Scrambling the data helps eliminate these peaks and spread the signal power more uniformly over the entire channel bandwidth. This uniform spectral density is required by FCC regulations to prevent excessive EMI from being radiated by the physical wiring.

The seed for the scrambler is generated from the transceiver address, PHYAD[4:0], ensuring that in multiple-transceiver applications, such as repeaters or switches, each transceiver will have its own scrambler sequence.

The scrambler also performs the Parallel In Serial Out conversion (PISO) of the data.

4.2.4 NRZI and MLT3 Encoding

The scrambler block passes the 5-bit wide parallel data to the NRZI converter where it becomes a serial 125MHz NRZI data stream. The NRZI is encoded to MLT-3. MLT3 is a tri-level code where a change in the logic level represents a code bit "1" and the logic output remaining at the same level represents a code bit "0".

4.2.5 100M Transmit Driver

The MLT3 data is then passed to the analog transmitter, which drives the differential MLT-3 signal, on outputs TXP and TXN, to the twisted pair media across a 1:1 ratio isolation transformer. The 10Base-T and 100Base-TX signals pass through the same transformer so that common "magnetics" can be used for both. The transmitter drives into the 100Ω impedance of the CAT-5 cable. Cable termination and impedance matching require external components.

4.2.6 100M Phase Lock Loop (PLL)

- The 100M PLL locks onto reference clock and generates the 125MHz clock used to drive the 125 MHz logic and the 100Base-Tx Transmitter.

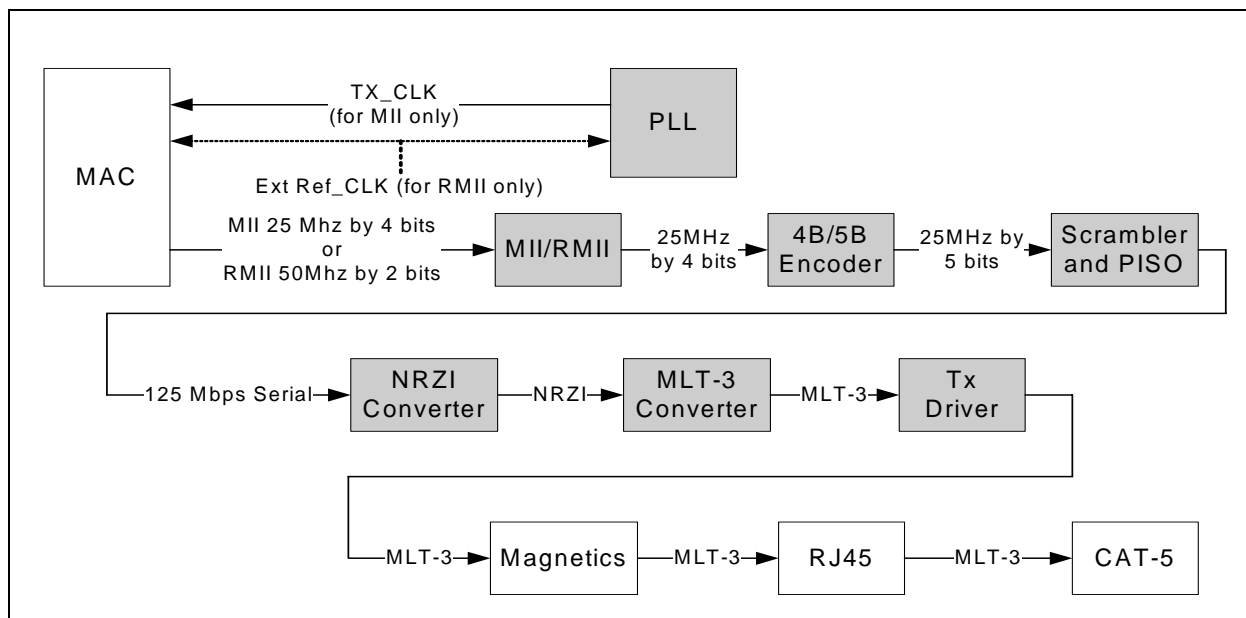

Figure 4.2 Receive Data Path

4.3 100Base-TX Receive

The receive data path is shown in [Figure 4.2](#). Detailed descriptions are given below.

4.3.1 100M Receive Input

The MLT-3 from the cable is fed into the transceiver (on inputs RXP and RXN) via a 1:1 ratio transformer. The ADC samples the incoming differential signal at a rate of 125M samples per second. Using a 64-level quantizer it generates 6 digital bits to represent each sample. The DSP adjusts the gain of the ADC according to the observed signal levels such that the full dynamic range of the ADC can be used.

4.3.2 Equalizer, Baseline Wander Correction and Clock and Data Recovery

The 6 bits from the ADC are fed into the DSP block. The equalizer in the DSP section compensates for phase and amplitude distortion caused by the physical channel consisting of magnetics, connectors, and CAT-5 cable. The equalizer can restore the signal for any good-quality CAT-5 cable between 1m and 150m.

If the DC content of the signal is such that the low-frequency components fall below the low frequency pole of the isolation transformer, then the droop characteristics of the transformer will become significant and Baseline Wander (BLW) on the received signal will result. To prevent corruption of the received data, the transceiver corrects for BLW and can receive the ANSI X3.263-1995 FDDI TP-PMD defined "killer packet" with no bit errors.

The 100M PLL generates multiple phases of the 125MHz clock. A multiplexer, controlled by the timing unit of the DSP, selects the optimum phase for sampling the data. This is used as the received recovered clock. This clock is used to extract the serial data from the received signal.

Datasheet

4.3.3 NRZI and MLT-3 Decoding

The DSP generates the MLT-3 recovered levels that are fed to the MLT-3 converter. The MLT-3 is then converted to an NRZI data stream.

4.3.4 Descrambling

The descrambler performs an inverse function to the scrambler in the transmitter and also performs the Serial In Parallel Out (SIPO) conversion of the data.

During reception of IDLE (/I/) symbols, the descrambler synchronizes its descrambler key to the incoming stream. Once synchronization is achieved, the descrambler locks on this key and is able to descramble incoming data.

Special logic in the descrambler ensures synchronization with the remote transceiver by searching for IDLE symbols within a window of 4000 bytes (40us). This window ensures that a maximum packet size of 1514 bytes, allowed by the IEEE 802.3 standard, can be received with no interference. If no IDLE-symbols are detected within this time-period, receive operation is aborted and the descrambler re-starts the synchronization process.

The descrambler can be bypassed by setting bit 0 of register 31.

4.3.5 Alignment

The de-scrambled signal is then aligned into 5-bit code-groups by recognizing the /J/K/ Start-of-Stream Delimiter (SSD) pair at the start of a packet. Once the code-word alignment is determined, it is stored and utilized until the next start of frame.

4.3.6 5B/4B Decoding

The 5-bit code-groups are translated into 4-bit data nibbles according to the 4B/5B table. The translated data is presented on the RXD[3:0] signal lines. The SSD, /J/K/, is translated to "0101 0101" as the first 2 nibbles of the MAC preamble. Reception of the SSD causes the transceiver to assert the RXDV signal, indicating that valid data is available on the RXD bus. Successive valid code-groups are translated to data nibbles. Reception of either the End of Stream Delimiter (ESD) consisting of the /T/R/ symbols, or at least two /I/ symbols causes the transceiver to de-assert carrier sense and RXDV.

These symbols are not translated into data.

The decoding process may be bypassed by clearing bit 6 of register 31. When the decoding is bypassed the 5th receive data bit is driven out on RXER/RXD4/PHYAD0. Decoding may be bypassed only when the MAC interface is in MII mode.

4.3.7 Receive Data Valid Signal

The Receive Data Valid signal (RXDV) indicates that recovered and decoded nibbles are being presented on the RXD[3:0] outputs synchronous to RXCLK. RXDV becomes active after the /J/K/ delimiter has been recognized and RXD is aligned to nibble boundaries. It remains active until either the /T/R/ delimiter is recognized or link test indicates failure or SIGDET becomes false.

RXDV is asserted when the first nibble of translated /J/K/ is ready for transfer over the Media Independent Interface (MII mode).

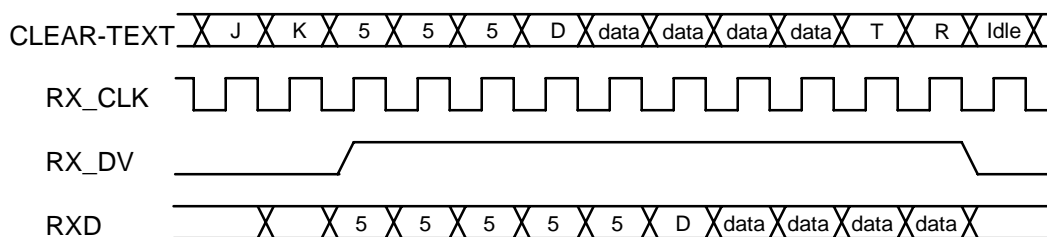

Figure 4.3 Relationship Between Received Data and Specific MII Signals

4.3.8 Receiver Errors

During a frame, unexpected code-groups are considered receive errors. Expected code groups are the DATA set (0 through F), and the /T/R/ (ESD) symbol pair. When a receive error occurs, the RXER signal is asserted and arbitrary data is driven onto the RXD[3:0] lines. Should an error be detected during the time that the /J/K/ delimiter is being decoded (bad SSD error), RXER is asserted true and the value '1110' is driven onto the RXD[3:0] lines. Note that the Valid Data signal is not yet asserted when the bad SSD error occurs.

4.3.9 100M Receive Data Across the MII/RMII Interface

In MII mode, the 4-bit data nibbles are sent to the MII block. These data nibbles are clocked to the controller at a rate of 25MHz. The controller samples the data on the rising edge of RXCLK. To ensure that the setup and hold requirements are met, the nibbles are clocked out of the transceiver on the falling edge of RXCLK. RXCLK is the 25MHz output clock for the MII bus. It is recovered from the received data to clock the RXD bus. If there is no received signal, it is derived from the system reference clock (XTAL1/CLKIN).

When tracking the received data, RXCLK has a maximum jitter of 0.8ns (provided that the jitter of the input clock, XTAL1/CLKIN, is below 100ps).

In RMII mode, the 2-bit data nibbles are sent to the RMII block. These data nibbles are clocked to the controller at a rate of 50MHz. The controller samples the data on the rising edge of XTAL1/CLKIN (REF_CLK). To ensure that the setup and hold requirements are met, the nibbles are clocked out of the transceiver on the falling edge of XTAL1/CLKIN (REF_CLK).

4.4 10Base-T Transmit

Data to be transmitted comes from the MAC layer controller. The 10Base-T transmitter receives 4-bit nibbles from the MII at a rate of 2.5MHz and converts them to a 10Mbps serial data stream. The data stream is then Manchester-encoded and sent to the analog transmitter, which drives a signal onto the twisted pair via the external magnetics.

The 10M transmitter uses the following blocks:

- MII (digital)
- TX 10M (digital)
- 10M Transmitter (analog)
- 10M PLL (analog)

4.4.1 10M Transmit Data Across the MII/RMII Interface

The MAC controller drives the transmit data onto the TXD BUS. For MII, when the controller has driven TXEN high to indicate valid data, the data is latched by the MII block on the rising edge of TXCLK. The data is in the form of 4-bit wide 2.5MHz data.

Datasheet

In order to comply with legacy 10Base-T MAC/Controllers, in Half-duplex mode the transceiver loops back the transmitted data, on the receive path. This does not confuse the MAC/Controller since the COL signal is not asserted during this time. The transceiver also supports the SQE (Heartbeat) signal. See [Section 5.3.2, "Collision Detect," on page 49](#), for more details.

For RMII, TXD[1:0] shall transition synchronously with respect to REF_CLK. When TXEN is asserted, TXD[1:0] are accepted for transmission by the LAN8710/LAN8710i. TXD[1:0] shall be "00" to indicate idle when TXEN is deasserted. Values of TXD[1:0] other than "00" when TXEN is deasserted are reserved for out-of-band signalling (to be defined). Values other than "00" on TXD[1:0] while TXEN is deasserted shall be ignored by the LAN8710/LAN8710i. TXD[1:0] shall provide valid data for each REF_CLK period while TXEN is asserted.

4.4.2 Manchester Encoding

The 4-bit wide data is sent to the TX10M block. The nibbles are converted to a 10Mbps serial NRZI data stream. The 10M PLL locks onto the external clock or internal oscillator and produces a 20MHz clock. This is used to Manchester encode the NRZ data stream. When no data is being transmitted (TXEN is low), the TX10M block outputs Normal Link Pulses (NLPs) to maintain communications with the remote link partner.

4.4.3 10M Transmit Drivers

The Manchester encoded data is sent to the analog transmitter where it is shaped and filtered before being driven out as a differential signal across the TXP and TXN outputs.

4.5 10Base-T Receive

The 10Base-T receiver gets the Manchester- encoded analog signal from the cable via the magnetics. It recovers the receive clock from the signal and uses this clock to recover the NRZI data stream. This 10M serial data is converted to 4-bit data nibbles which are passed to the controller across the MII at a rate of 2.5MHz.

This 10M receiver uses the following blocks:

- Filter and SQUELCH (analog)
- 10M PLL (analog)
- RX 10M (digital)
- MII (digital)

4.5.1 10M Receive Input and Squelch

The Manchester signal from the cable is fed into the transceiver (on inputs RXP and RXN) via 1:1 ratio magnetics. It is first filtered to reduce any out-of-band noise. It then passes through a SQUELCH circuit. The SQUELCH is a set of amplitude and timing comparators that normally reject differential voltage levels below 300mV and detect and recognize differential voltages above 585mV.

4.5.2 Manchester Decoding

The output of the SQUELCH goes to the RX10M block where it is validated as Manchester encoded data. The polarity of the signal is also checked. If the polarity is reversed (local RXP is connected to RXN of the remote partner and vice versa), then this is identified and corrected. The reversed condition is indicated by the flag "XPOL", bit 4 in register 27. The 10M PLL is locked onto the received Manchester signal and from this, generates the received 20MHz clock. Using this clock, the Manchester encoded data is extracted and converted to a 10MHz NRZI data stream. It is then converted from serial to 4-bit wide parallel data.

The RX10M block also detects valid 10Base-T IDLE signals - Normal Link Pulses (NLPs) - to maintain the link.

4.5.3 10M Receive Data Across the MII/RMII Interface

For MII, the 4 bit data nibbles are sent to the MII block. In MII mode, these data nibbles are valid on the rising edge of the 2.5 MHz RXCLK.

For RMII, the 2bit data nibbles are sent to the RMII block. In RMII mode, these data nibbles are valid on the rising edge of the RMII REF_CLK.

4.5.4 Jabber Detection

Jabber is a condition in which a station transmits for a period of time longer than the maximum permissible packet length, usually due to a fault condition, that results in holding the TXEN input for a long period. Special logic is used to detect the jabber state and abort the transmission to the line, within 45ms. Once TXEN is deasserted, the logic resets the jabber condition.

As shown in [Table 5.22](#), bit 1.1 indicates that a jabber condition was detected.

4.6 MAC Interface

The MII/RMII block is responsible for the communication with the controller. Special sets of hand-shake signals are used to indicate that valid received/transmitted data is present on the 4 bit receive/transmit bus.

The device must be configured in MII or RMII mode. This is done by specific pin strapping configurations.

See [Section 4.6.3, "MII vs. RMII Configuration," on page 27](#) for information on pin strapping and how the pins are mapped differently.

4.6.1 MII

The MII includes 16 interface signals:

- transmit data - TXD[3:0]
- transmit strobe - TXEN
- transmit clock - TXCLK
- transmit error - TXER/TXD4
- receive data - RXD[3:0]
- receive strobe - RXDV
- receive clock - RXCLK
- receive error - RXER/RXD4/PHYAD0
- collision indication - COL
- carrier sense - CRS

In MII mode, on the transmit path, the transceiver drives the transmit clock, TXCLK, to the controller. The controller synchronizes the transmit data to the rising edge of TXCLK. The controller drives TXEN high to indicate valid transmit data. The controller drives TXER high when a transmit error is detected.

On the receive path, the transceiver drives both the receive data, RXD[3:0], and the RXCLK signal. The controller clocks in the receive data on the rising edge of RXCLK when the transceiver drives RXDV high. The transceiver drives RXER high when a receive error is detected.

4.6.2 RMII

The SMSC LAN8710 supports the low pin count Reduced Media Independent Interface (RMII) intended for use between Ethernet transceivers and Switch ASICs. Under IEEE 802.3, an MII

Datasheet

comprised of 16 pins for data and control is defined. In devices incorporating many MACs or transceiver interfaces such as switches, the number of pins can add significant cost as the port counts increase. The management interface (MDIO/MDC) is identical to MII. The RMII interface has the following characteristics:

- It is capable of supporting 10Mb/s and 100Mb/s data rates
- A single clock reference is used for both transmit and receive.
- It provides independent 2 bit wide (di-bit) transmit and receive data paths
- It uses LVCMOS signal levels, compatible with common digital CMOS ASIC processes

The RMII includes 6 interface signals with one of the signals being optional:

- transmit data - TXD[1:0]
- transmit strobe - TXEN
- receive data - RXD[1:0]
- receive error - RXER (Optional)
- carrier sense - CRS_DV
- Reference Clock - (RMII references usually define this signal as REF_CLK)

4.6.2.1 CRS_DV - Carrier Sense/Receive Data Valid

The CRS_DV is asserted by the LAN8710/LAN8710i when the receive medium is non-idle. CRS_DV is asserted asynchronously on detection of carrier due to the criteria relevant to the operating mode. That is, in 10BASE-T mode, when squelch is passed or in 100BASE-X mode when 2 non-contiguous zeroes in 10 bits are detected, carrier is said to be detected.

Loss of carrier shall result in the deassertion of CRS_DV synchronous to the cycle of REF_CLK which presents the first di-bit of a nibble onto RXD[1:0] (i.e. CRS_DV is deasserted only on nibble boundaries). If the LAN8710/LAN8710i has additional bits to be presented on RXD[1:0] following the initial deassertion of CRS_DV, then the LAN8710/LAN8710i shall assert CRS_DV on cycles of REF_CLK which present the second di-bit of each nibble and de-assert CRS_DV on cycles of REF_CLK which present the first di-bit of a nibble. The result is: Starting on nibble boundaries CRS_DV toggles at 25 MHz in 100Mb/s mode and 2.5 MHz in 10Mb/s mode when CRS ends before RXDV (i.e. the FIFO still has bits to transfer when the carrier event ends.) Therefore, the MAC can accurately recover RXDV and CRS.

During a false carrier event, CRS_DV shall remain asserted for the duration of carrier activity. The data on RXD[1:0] is considered valid once CRS_DV is asserted. However, since the assertion of CRS_DV is asynchronous relative to REF_CLK, the data on RXD[1:0] shall be "00" until proper receive signal decoding takes place.

4.6.3 MII vs. RMII Configuration

The LAN8710/LAN8710i must be configured to support the MII or RMII bus for connectivity to the MAC. This configuration is done through the RXD2/RMIISEL pin.

MII or RMII mode selection is configured based on the strapping of the RXD2/RMIISEL pin as described in [Section 5.3.9.3](#).

Most of the MII and RMII pins are multiplexed. [Table 4.2, "MII/RMII Signal Mapping"](#) describes the relationship of the related device pins to the MII and RMII mode signal names.

Table 4.2 MII/RMII Signal Mapping

LAN8710 PIN NAME	MII MODE	RMII MODE
TXD0	TXD0	TXD0
TXD1	TXD1	TXD1
TXEN	TXEN	TXEN
RXER/ RXD4/PHYAD0	RXER	RXER Note 4.2
COL/CRS_DV/MODE2	COL	CRS_DV
RXD0/MODE0	RXD0	RXD0
RXD1/MODE1	RXD1	RXD1
TXD2	TXD2	Note 4.1
TXD3	TXD3	Note 4.1
nINT/TXER/TXD4	TXER/ TXD4	
CRS	CRS	
RXDV	RXDV	
RXD2/RMIISEL	RXD2	
RXD3/PHYAD2	RXD3	
TXCLK	TXCLK	
RXCLK/PHYAD1	RXCLK	
XTAL1/CLKIN	XTAL1/CLKIN	REF_CLK

Note 4.1 In RMII mode, this pin needs to be tied to VSS.

Note 4.2 The RXER signal is optional on the RMII bus. This signal is required by the transceiver, but it is optional for the MAC. The MAC can choose to ignore or not use this signal.

The RMII REF_CLK is a continuous clock that provides the timing reference for CRS_DV, RXD[1:0], TXEN, TXD[1:0] and RXER. The LAN8710 uses REF_CLK as the network clock such that no buffering is required on the transmit data path. However, on the receive data path, the receiver recovers the clock from the incoming data stream, and the LAN8710 uses elasticity buffering to accommodate for differences between the recovered clock and the local REF_CLK.

4.7 Auto-negotiation

The purpose of the Auto-negotiation function is to automatically configure the transceiver to the optimum link parameters based on the capabilities of its link partner. Auto-negotiation is a mechanism for exchanging configuration information between two link-partners and automatically selecting the highest performance mode of operation supported by both sides. Auto-negotiation is fully defined in clause 28 of the IEEE 802.3 specification.

Once auto-negotiation has completed, information about the resolved link can be passed back to the controller via the Serial Management Interface (SMI). The results of the negotiation process are reflected in the Speed Indication bits in register 31, as well as the Link Partner Ability Register (Register 5).



Datasheet

The auto-negotiation protocol is a purely physical layer activity and proceeds independently of the MAC controller.

The advertised capabilities of the transceiver are stored in register 4 of the SMI registers. The default advertised by the transceiver is determined by user-defined on-chip signal options.

The following blocks are activated during an Auto-negotiation session:

- Auto-negotiation (digital)
- 100M ADC (analog)
- 100M PLL (analog)
- 100M equalizer/BLW/clock recovery (DSP)
- 10M SQUELCH (analog)
- 10M PLL (analog)
- 10M Transmitter (analog)

When enabled, auto-negotiation is started by the occurrence of one of the following events:

- Hardware reset
- Software reset
- Power-down reset
- Link status down
- Setting register 0, bit 9 high (auto-negotiation restart)

On detection of one of these events, the transceiver begins auto-negotiation by transmitting bursts of Fast Link Pulses (FLP). These are bursts of link pulses from the 10M transmitter. They are shaped as Normal Link Pulses and can pass uncorrupted down CAT-3 or CAT-5 cable. A Fast Link Pulse Burst consists of up to 33 pulses. The 17 odd-numbered pulses, which are always present, frame the FLP burst. The 16 even-numbered pulses, which may be present or absent, contain the data word being transmitted. Presence of a data pulse represents a "1", while absence represents a "0".

The data transmitted by an FLP burst is known as a "Link Code Word." These are defined fully in IEEE 802.3 clause 28. In summary, the transceiver advertises 802.3 compliance in its selector field (the first 5 bits of the Link Code Word). It advertises its technology ability according to the bits set in register 4 of the SMI registers.

There are 4 possible matches of the technology abilities. In the order of priority these are:

- 100M Full Duplex (Highest priority)
- 100M Half Duplex
- 10M Full Duplex
- 10M Half Duplex

If the full capabilities of the transceiver are advertised (100M, Full Duplex), and if the link partner is capable of 10M and 100M, then auto-negotiation selects 100M as the highest performance mode. If the link partner is capable of Half and Full duplex modes, then auto-negotiation selects Full Duplex as the highest performance operation.

Once a capability match has been determined, the link code words are repeated with the acknowledge bit set. Any difference in the main content of the link code words at this time will cause auto-negotiation to re-start. Auto-negotiation will also re-start if not all of the required FLP bursts are received.

The capabilities advertised during auto-negotiation by the transceiver are initially determined by the logic levels latched on the MODE[2:0] bus after reset completes. This bus can also be used to disable auto-negotiation on power-up.

Writing register 4 bits [8:5] allows software control of the capabilities advertised by the transceiver. Writing register 4 does not automatically re-start auto-negotiation. Register 0, bit 9 must be set before the new abilities will be advertised. Auto-negotiation can also be disabled via software by clearing register 0, bit 12.

The LAN8710/LAN8710i does not support “Next Page” capability.

4.7.1 Parallel Detection

If the LAN8710/LAN8710i is connected to a device lacking the ability to auto-negotiate (i.e. no FLPs are detected), it is able to determine the speed of the link based on either 100M MLT-3 symbols or 10M Normal Link Pulses. In this case the link is presumed to be Half Duplex per the IEEE standard. This ability is known as “Parallel Detection.” This feature ensures interoperability with legacy link partners. If a link is formed via parallel detection, then bit 0 in register 6 is cleared to indicate that the Link Partner is not capable of auto-negotiation. The controller has access to this information via the management interface. If a fault occurs during parallel detection, bit 4 of register 6 is set.

Register 5 is used to store the Link Partner Ability information, which is coded in the received FLPs. If the Link Partner is not auto-negotiation capable, then register 5 is updated after completion of parallel detection to reflect the speed capability of the Link Partner.

4.7.2 Re-starting Auto-negotiation

Auto-negotiation can be re-started at any time by setting register 0, bit 9. Auto-negotiation will also re-start if the link is broken at any time. A broken link is caused by signal loss. This may occur because of a cable break, or because of an interruption in the signal transmitted by the Link Partner. Auto-negotiation resumes in an attempt to determine the new link configuration.

If the management entity re-starts Auto-negotiation by writing to bit 9 of the control register, the LAN8710/LAN8710i will respond by stopping all transmission/receiving operations. Once the break_link_timer is done, in the Auto-negotiation state-machine (approximately 1200ms) the auto-negotiation will re-start. The Link Partner will have also dropped the link due to lack of a received signal, so it too will resume auto-negotiation.

4.7.3 Disabling Auto-negotiation

Auto-negotiation can be disabled by setting register 0, bit 12 to zero. The device will then force its speed of operation to reflect the information in register 0, bit 13 (speed) and register 0, bit 8 (duplex). The speed and duplex bits in register 0 should be ignored when auto-negotiation is enabled.

4.7.4 Half vs. Full Duplex

Half Duplex operation relies on the CSMA/CD (Carrier Sense Multiple Access / Collision Detect) protocol to handle network traffic and collisions. In this mode, the carrier sense signal, CRS, responds to both transmit and receive activity. In this mode, if data is received while the transceiver is transmitting, a collision results.

In Full Duplex mode, the transceiver is able to transmit and receive data simultaneously. In this mode, CRS responds only to receive activity. The CSMA/CD protocol does not apply and collision detection is disabled.

4.8 HP Auto-MDIX Support

HP Auto-MDIX facilitates the use of CAT-3 (10 Base-T) or CAT-5 (100 Base-T) media UTP interconnect cable without consideration of interface wiring scheme. If a user plugs in either a direct connect LAN cable, or a cross-over patch cable, as shown in [Figure 4.4](#), the SMSC LAN8710/LAN8710i Auto-MDIX transceiver is capable of configuring the TXP/TXN and RXP/RXN pins for correct transceiver operation.

Datasheet

The internal logic of the device detects the TX and RX pins of the connecting device. Since the RX and TX line pairs are interchangeable, special PCB design considerations are needed to accommodate the symmetrical magnetics and termination of an Auto-MDIX design.

The Auto-MDIX function can be disabled using the Special Control/Status Indications register (bit 27.15).

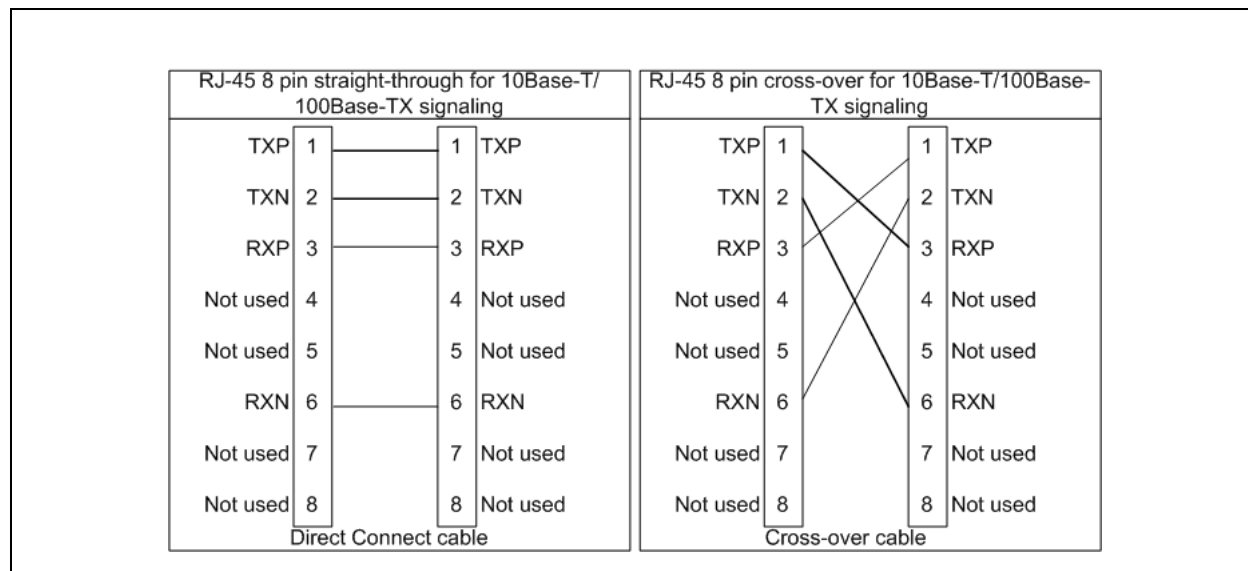

Figure 4.4 Direct Cable Connection vs. Cross-over Cable Connection

4.9 Internal +1.2V Regulator Disable

One feature of the flexPWR technology is the ability to configure the internal 1.2V regulator off. When the regulator is disabled, external 1.2V must be supplied to VDDCR. This makes it possible to reduce total system power, since an external switching regulator with greater efficiency than the internal linear regulator may be used to provide the +1.2V to the transceiver circuitry.

4.9.1 Disable the Internal +1.2V Regulator

To disable the +1.2V internal regulator, a pullup strapping resistor is connected from LED1/REGOFF to VDD2A. At power-on, after both VDDIO and VDD2A are within specification, the transceiver will sample the LED1/REGOFF pin to determine if the internal regulator should turn on. If the pin is sampled at a voltage greater than V_{IH} , then the internal regulator is disabled, and the system must supply +1.2V to the VDDCR pin. As described in Section 4.9.2, when the LED1/REGOFF pin is left floating or connected to VSS, then the internal regulator is enabled and the system is not required to supply +1.2V to the VDDCR pin.

4.9.2 Enable the Internal +1.2V Regulator

The 1.2V for VDDCR is supplied by the on-chip regulator unless the transceiver is configured for regulator off mode using the LED1/REGOFF pin as described in Section 4.9.1. By default, the internal +1.2V regulator is enabled when the LED1/REGOFF pin is floating. As shown in Table 7.10, an internal pull-down resistor straps the regulator on if the LED1/REGOFF pin is floating.

During VDDIO and VDDA power-on, if the LED1/REGOFF pin is sampled below V_{IL} , then the internal +1.2V regulator will turn on and operate with power from the VDD2A pin.

4.10 nINTSEL Strapping and LED Polarity Selection

The nINT, TXER, and TXD4 functions share a common pin. There are two functional modes for this pin, the TXER/TXD4 mode and nINT (interrupt) mode.

The nINTSEL pin is shared with the LED2 pin. The LED2 output will automatically change polarity based on the presence of an external pull-down resistor. If the LED pin is pulled high (by the internal pull-up resistor) to select a logical high for nINTSEL, then the LED output will be active low. If the LED pin is pulled low by an external pull-down resistor to select a logical low nINTSEL, the LED output will then be an active high output.

To set nINTSEL without LEDs, float the pin to set nINTSEL high or pull-down the pin with an external resistor to GND to set nINTSEL low. See [Figure 4.5](#).

The LED2/nINTSEL pin is latched on the rising edge of the nRST. The default setting is to float the pin high for nINT mode.

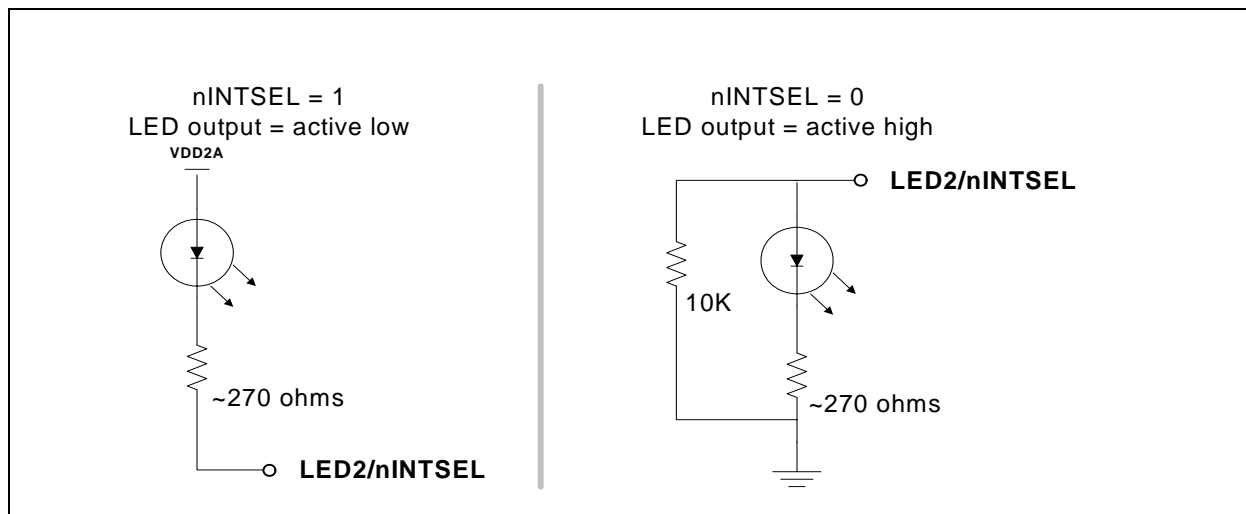

Figure 4.5 nINTSEL Strapping on LED2

4.11 REGOFF and LED Polarity Selection

The REGOFF configuration pin is shared with the LED1 pin. The LED1 output will automatically change polarity based on the presence of an external pull-up resistor. If the LED pin is pulled high to VDD2A by an external pull-up resistor to select a logical high for REGOFF, then the LED output will be active low. If the LED pin is pulled low by the internal pull-down resistor to select a logical low for REGOFF, the LED output will then be an active high output.

To set REGOFF without LEDs, pull-up the pin with an external resistor to VDDIO to disable the regulator. See [Figure 4.6](#).

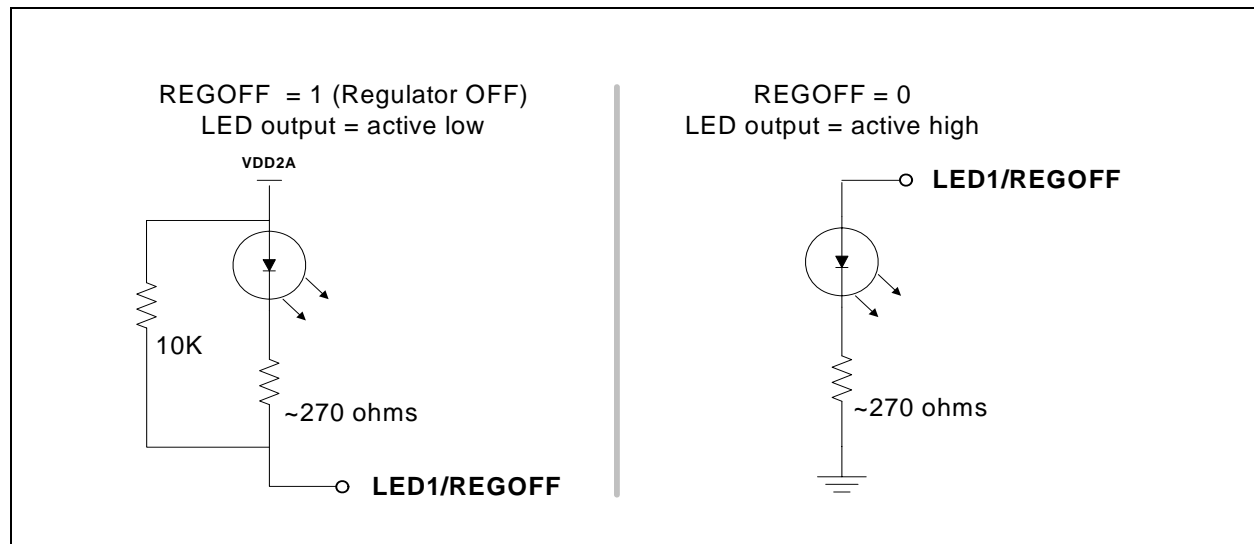

Figure 4.6 REGOFF Configuration on LED1

4.12 PHY Address Strapping

The PHY ADDRESS bits are latched into an internal register at the end of a hardware reset. The 3-bit address word[2:0] is input on the PHYAD[2:0] pins. The default setting is 3'b000 as described in [Section 5.3.9.1](#).

4.13 Variable Voltage I/O

The Digital I/O pins on the LAN8710/LAN8710i are variable voltage to take advantage of low power savings from shrinking technologies. These pins can operate from a low I/O voltage of +1.8V-10% up to +3.3V+10%. The I/O voltage the System Designer applies on VDDIO needs to maintain its value with a tolerance of $\pm 10\%$. Varying the voltage up or down, after the transceiver has completed power-on reset can cause errors in the transceiver operation.

4.14 Transceiver Management Control

The Management Control module includes 3 blocks:

- Serial Management Interface (SMI)
- Management Registers Set
- Interrupt

4.14.1 Serial Management Interface (SMI)

The Serial Management Interface is used to control the LAN8710/LAN8710i and obtain its status. This interface supports registers 0 through 6 as required by Clause 22 of the 802.3 standard, as well as “vendor-specific” registers 16 to 31 allowed by the specification. Non-supported registers (7 to 15) will be read as hexadecimal “FFFF”.

At the system level there are 2 signals, MDIO and MDC where MDIO is bi-directional open-drain and MDC is the clock.

A special feature (enabled by register 17 bit 3) forces the transceiver to disregard the PHY-Address in the SMI packet causing the transceiver to respond to any address. This feature is useful in multi-PHY

applications and in production testing, where the same register can be written in all the transceivers using a single write transaction.

The MDC signal is an aperiodic clock provided by the station management controller (SMC). The MDIO signal receives serial data (commands) from the controller SMC, and sends serial data (status) to the SMC. The minimum time between edges of the MDC is 160 ns. There is no maximum time between edges.

The minimum cycle time (time between two consecutive rising or two consecutive falling edges) is 400 ns. These modest timing requirements allow this interface to be easily driven by the I/O port of a microcontroller.

The data on the MDIO line is latched on the rising edge of the MDC. The frame structure and timing of the data is shown in [Figure 4.7](#) and [Figure 4.8](#).

The timing relationships of the MDIO signals are further described in [Section 6.1, "Serial Management Interface \(SMI\) Timing,"](#) on page 55.

Read Cycle

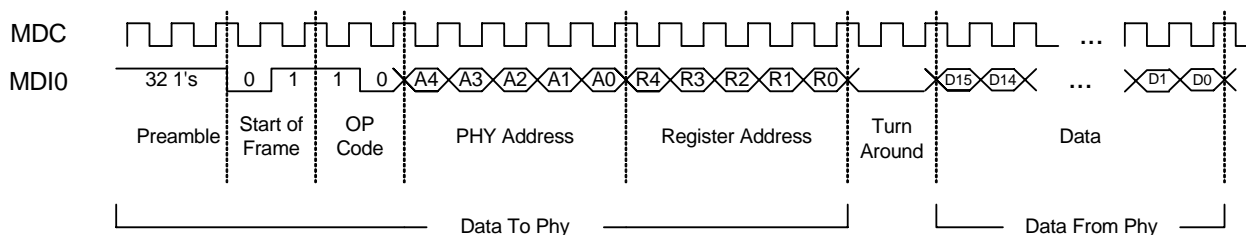

Figure 4.7 MDIO Timing and Frame Structure - READ Cycle

Write Cycle

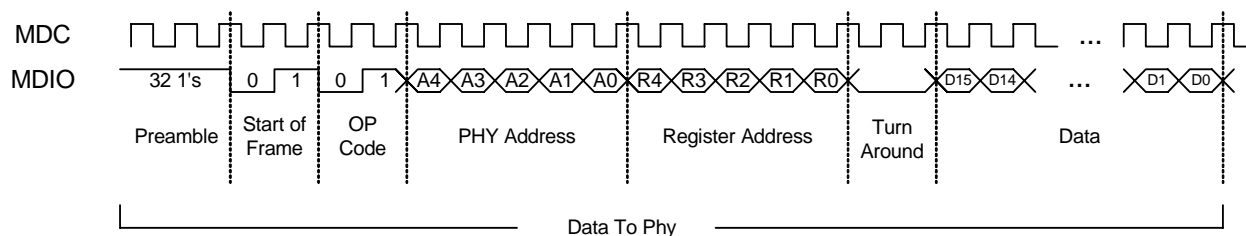

Figure 4.8 MDIO Timing and Frame Structure - WRITE Cycle

Chapter 5 SMI Register Mapping

Revision 1.0 (04-15-09)

Table 5.1 Control Register: Register 0 (Basic)

15	14	13	12	11	10	9	8	7	6	5	4	3	2	1	0
Reset	Loopback	Speed Select	A/N Enable	Power Down	Isolate	Restart A/N	Duplex Mode	Collision Test	Reserved						

Table 5.2 Status Register: Register 1 (Basic)

15	14	13	12	11	10	9	8	7	6	5	4	3	2	1	0
100Base-T4	100Base-TX Full Duplex	100Base-TX Half Duplex	10Base-T Full Duplex	10Base-T Half Duplex	Reserved					A/N Complete	Remote Fault	A/N Ability	Link Status	Jabber Detect	Extended Capability

Table 5.3 PHY ID 1 Register: Register 2 (Extended)

15	14	13	12	11	10	9	8	7	6	5	4	3	2	1	0
PHY ID Number (Bits 3-18 of the Organizationally Unique Identifier - OUI)															

Table 5.4 PHY ID 2 Register: Register 3 (Extended)

15	14	13	12	11	10	9	8	7	6	5	4	3	2	1	0
PHY ID Number (Bits 19-24 of the Organizationally Unique Identifier - OUI)						Manufacturer Model Number						Manufacturer Revision Number			

35
DATASHEET

SMSC LAN8710/LAN8710i

Table 5.5 Auto-Negotiation Advertisement: Register 4 (Extended)

15	14	13	12	11	10	9	8	7	6	5	4	3	2	1	0
Next Page	Reserved	Remote Fault	Reserved	Pause Operation		100Base-T4	100Base-TX Full Duplex	100Base-TX	10Base-T Full Duplex	10Base-T	IEEE 802.3 Selector Field				

Table 5.6 Auto-Negotiation Link Partner Base Page Ability Register: Register 5 (Extended)

15	14	13	12	11	10	9	8	7	6	5	4	3	2	1	0
Next Page	Acknowledge	Remote Fault	Reserved	Pause	100Base-T4	100Base-TX Full Duplex	100Base-TX	10Base-T Full Duplex	10Base-T	IEEE 802.3 Selector Field					

Table 5.7 Auto-Negotiation Expansion Register: Register 6 (Extended)

15	14	13	12	11	10	9	8	7	6	5	4	3	2	1	0
Reserved											Parallel Detect Fault	Link Partner Next Page Able	Next Page Able	Page Received	Link Partner A/N Able

Table 5.8 Register 15 (Extended)

15	14	13	12	11	10	9	8	7	6	5	4	3	2	1	0
IEEE Reserved															

Table 5.9 Silicon Revision Register 16: Vendor-Specific

15	14	13	12	11	10	9	8	7	6	5	4	3	2	1	0
Reserved						Silicon Revision				Reserved					

Table 5.10 Mode Control/ Status Register 17: Vendor-Specific

15	14	13	12	11	10	9	8	7	6	5	4	3	2	1	0
RSVD	EDPWRDOWN	RSVD	LOWSQEN	MDPREBP	FARLOOPBACK	RSVD	ALTINT	RSVD	PHYADBP	Force Good Link Status	ENERGYON	RSVD			

RSVD = Reserved

Table 5.11 Special Modes Register 18: Vendor-Specific

15	14	13	12	11	10	9	8	7	6	5	4	3	2	1	0
Reserved	MIIMODE	Reserved						MODE			PHYAD				

Table 5.12 Register 24: Vendor-Specific

15	14	13	12	11	10	9	8	7	6	5	4	3	2	1	0
Reserved															

Table 5.13 Register 25: Vendor-Specific

15	14	13	12	11	10	9	8	7	6	5	4	3	2	1	0
Reserved															

Table 5.14 Symbol Error Counter Register 26: Vendor-Specific

15	14	13	12	11	10	9	8	7	6	5	4	3	2	1	0
Symbol Error Counter															

Table 5.15 Special Control/Status Indications Register 27: Vendor-Specific

15	14	13	12	11	10	9	8	7	6	5	4	3	2	1	0
AMDIXCTRL	Reserved	CH_SELECT	Reserved	SQEOFF	Reserved					XPOL	Reserved				

Table 5.16 Special Internal Testability Control Register 28: Vendor-Specific

15	14	13	12	11	10	9	8	7	6	5	4	3	2	1	0
Reserved															

Table 5.17 Interrupt Source Flags Register 29: Vendor-Specific

15	14	13	12	11	10	9	8	7	6	5	4	3	2	1	0
Reserved							INT7	INT6	INT5	INT4	INT3	INT2	INT1	Reserved	

Table 5.18 Interrupt Mask Register 30: Vendor-Specific

15	14	13	12	11	10	9	8	7	6	5	4	3	2	1	0
Reserved							Mask Bits							Reserved	

Table 5.19 PHY Special Control/Status Register 31: Vendor-Specific

15	14	13	12	11	10	9	8	7	6	5	4	3	2	1	0
Reserved		Autodone	Reserved	GPO2	GPO1	GPO0	Enable 4B5B	Reserved	Speed Indication			Reserved	Scramble Disable		



Datasheet

The following registers are supported (register numbers are in decimal):

Table 5.20 SMI Register Mapping

REGISTER #	DESCRIPTION	Group
0	Basic Control Register	Basic
1	Basic Status Register	Basic
2	PHY Identifier 1	Extended
3	PHY Identifier 2	Extended
4	Auto-Negotiation Advertisement Register	Extended
5	Auto-Negotiation Link Partner Ability Register	Extended
6	Auto-Negotiation Expansion Register	Extended
16	Silicon Revision Register	Vendor-specific
17	Mode Control/Status Register	Vendor-specific
18	Special Modes	Vendor-specific
20	Reserved	Vendor-specific
21	Reserved	Vendor-specific
22	Reserved	Vendor-specific
23	Reserved	Vendor-specific
26	Symbol Error Counter Register	Vendor-specific
27	Control / Status Indication Register	Vendor-specific
28	Special internal testability controls	Vendor-specific
29	Interrupt Source Register	Vendor-specific
30	Interrupt Mask Register	Vendor-specific
31	PHY Special Control/Status Register	Vendor-specific

5.1 SMI Register Format

The mode key is as follows:

- RW = Read/write,
- SC = Self clearing,
- WO = Write only,
- RO = Read only,
- LH = Latch high, clear on read of register,
- LL = Latch low, clear on read of register,
- NASR = Not Affected by Software Reset
- X = Either a 1 or 0.

Table 5.21 Register 0 - Basic Control

ADDRESS	NAME	DESCRIPTION	MODE	DEFAULT
0.15	Reset	1 = software reset. Bit is self-clearing. For best results, when setting this bit do not set other bits in this register. The configuration (as described in Section 5.3.9.2) is set from the register bit values, and not from the mode pins.	RW/SC	0
0.14	Loopback	1 = loopback mode, 0 = normal operation	RW	0
0.13	Speed Select	1 = 100Mbps, 0 = 10Mbps. Ignored if Auto Negotiation is enabled (0.12 = 1).	RW	Set by MODE[2:0] bus
0.12	Auto-Negotiation Enable	1 = enable auto-negotiate process (overrides 0.13 and 0.8) 0 = disable auto-negotiate process	RW	Set by MODE[2:0] bus
0.11	Power Down	1 = General power down mode, 0 = normal operation	RW	0
0.10	Isolate	1 = electrical isolation of transceiver from MII 0 = normal operation	RW	0
0.9	Restart Auto-Negotiate	1 = restart auto-negotiate process 0 = normal operation. Bit is self-clearing.	RW/SC	0
0.8	Duplex Mode	1 = Full duplex, 0 = Half duplex. Ignored if Auto Negotiation is enabled (0.12 = 1).	RW	Set by MODE[2:0] bus
0.7	Collision Test	1 = enable COL test, 0 = disable COL test	RW	0
0.6:0	Reserved		RO	0

Table 5.22 Register 1 - Basic Status

ADDRESS	NAME	DESCRIPTION	MODE	DEFAULT
1.15	100Base-T4	1 = T4 able, 0 = no T4 ability	RO	0
1.14	100Base-TX Full Duplex	1 = TX with full duplex, 0 = no TX full duplex ability	RO	1
1.13	100Base-TX Half Duplex	1 = TX with half duplex, 0 = no TX half duplex ability	RO	1
1.12	10Base-T Full Duplex	1 = 10Mbps with full duplex 0 = no 10Mbps with full duplex ability	RO	1
1.11	10Base-T Half Duplex	1 = 10Mbps with half duplex 0 = no 10Mbps with half duplex ability	RO	1
1.10:6	Reserved			
1.5	Auto-Negotiate Complete	1 = auto-negotiate process completed 0 = auto-negotiate process not completed	RO	0



Datasheet

Table 5.22 Register 1 - Basic Status (continued)

ADDRESS	NAME	DESCRIPTION	MODE	DEFAULT
1.4	Remote Fault	1 = remote fault condition detected 0 = no remote fault	RO/ LH	0
1.3	Auto-Negotiate Ability	1 = able to perform auto-negotiation function 0 = unable to perform auto-negotiation function	RO	1
1.2	Link Status	1 = link is up, 0 = link is down	RO/ LL	X
1.1	Jabber Detect	1 = jabber condition detected 0 = no jabber condition detected	RO/ LH	X
1.0	Extended Capabilities	1 = supports extended capabilities registers 0 = does not support extended capabilities registers	RO	1

Table 5.23 Register 2 - PHY Identifier 1

ADDRESS	NAME	DESCRIPTION	MODE	DEFAULT
2.15:0	PHY ID Number	Assigned to the 3rd through 18th bits of the Organizationally Unique Identifier (OUI), respectively. OUI=00800Fh	RW	0007h

Table 5.24 Register 3 - PHY Identifier 2

ADDRESS	NAME	DESCRIPTION	MODE	DEFAULT
3.15:10	PHY ID Number	Assigned to the 19 th through 24 th bits of the OUI.	RW	30h
3.9:4	Model Number	Six-bit manufacturer's model number.	RW	0Fh
3.3:0	Revision Number	Four-bit manufacturer's revision number.	RW	DEVICE REV

Table 5.25 Register 4 - Auto Negotiation Advertisement

ADDRESS	NAME	DESCRIPTION	MODE	DEFAULT
4.15	Next Page	1 = next page capable, 0 = no next page ability This Phy does not support next page ability.	RO	0
4.14	Reserved		RO	0
4.13	Remote Fault	1 = remote fault detected, 0 = no remote fault	RW	0
4.12	Reserved			
4.11:10	Pause Operation	00 = No PAUSE 01= Symmetric PAUSE 10= Asymmetric PAUSE toward link partner 11 = Both Symmetric PAUSE and Asymmetric PAUSE toward local device	R/W	00

Table 5.25 Register 4 - Auto Negotiation Advertisement (continued)

ADDRESS	NAME	DESCRIPTION	MODE	DEFAULT
4.9	100Base-T4	1 = T4 able, 0 = no T4 ability This Phy does not support 100Base-T4.	RO	0
4.8	100Base-TX Full Duplex	1 = TX with full duplex, 0 = no TX full duplex ability	RW	Set by MODE[2:0] bus
4.7	100Base-TX	1 = TX able, 0 = no TX ability	RW	1
4.6	10Base-T Full Duplex	1 = 10Mbps with full duplex 0 = no 10Mbps with full duplex ability	RW	Set by MODE[2:0] bus
4.5	10Base-T	1 = 10Mbps able, 0 = no 10Mbps ability	RW	Set by MODE[2:0] bus
4.4:0	Selector Field	[00001] = IEEE 802.3	RW	00001

Table 5.26 Register 5 - Auto Negotiation Link Partner Ability

ADDRESS	NAME	DESCRIPTION	MODE	DEFAULT
5.15	Next Page	1 = "Next Page" capable, 0 = no "Next Page" ability This Phy does not support next page ability.	RO	0
5.14	Acknowledge	1 = link code word received from partner 0 = link code word not yet received	RO	0
5.13	Remote Fault	1 = remote fault detected, 0 = no remote fault	RO	0
5.12:11	Reserved		RO	0
5.10	Pause Operation	1 = Pause Operation is supported by remote MAC, 0 = Pause Operation is not supported by remote MAC	RO	0
5.9	100Base-T4	1 = T4 able, 0 = no T4 ability. This Phy does not support T4 ability.	RO	0
5.8	100Base-TX Full Duplex	1 = TX with full duplex, 0 = no TX full duplex ability	RO	0
5.7	100Base-TX	1 = TX able, 0 = no TX ability	RO	0
5.6	10Base-T Full Duplex	1 = 10Mbps with full duplex 0 = no 10Mbps with full duplex ability	RO	0
5.5	10Base-T	1 = 10Mbps able, 0 = no 10Mbps ability	RO	0
5.4:0	Selector Field	[00001] = IEEE 802.3	RO	00001

Table 5.27 Register 6 - Auto Negotiation Expansion

ADDRESS	NAME	DESCRIPTION	MODE	DEFAULT
6.15:5	Reserved		RO	0
6.4	Parallel Detection Fault	1 = fault detected by parallel detection logic 0 = no fault detected by parallel detection logic	RO/ LH	0
6.3	Link Partner Next Page Able	1 = link partner has next page ability 0 = link partner does not have next page ability	RO	0
6.2	Next Page Able	1 = local device has next page ability 0 = local device does not have next page ability	RO	0
6.1	Page Received	1 = new page received 0 = new page not yet received	RO/ LH	0
6.0	Link Partner Auto-Negotiation Able	1 = link partner has auto-negotiation ability 0 = link partner does not have auto-negotiation ability	RO	0

Table 5.28 Register 16 - Silicon Revision

ADDRESS	NAME	DESCRIPTION	MODE	DEFAULT
16.15:10	Reserved		RO	0
16.9:6	Silicon Revision	Four-bit silicon revision identifier.	RO	0001
16.5:0	Reserved		RO	0

Table 5.29 Register 17 - Mode Control/Status

ADDRESS	NAME	DESCRIPTION	MODE	DEFAULT
17.15:14	Reserved	Write as 0; ignore on read.	RW	0
17.13	EDPWRDOWN	Enable the Energy Detect Power-Down mode: 0 = Energy Detect Power-Down is disabled 1 = Energy Detect Power-Down is enabled	RW	0
17.12	Reserved	Write as 0, ignore on read	RW	0
17.11	LOWSQEN	The Low_Squelch signal is equal to LOWSQEN AND EDPWRDOWN. Low_Squelch = 1 implies a lower threshold (more sensitive). Low_Squelch = 0 implies a higher threshold (less sensitive).	RW	0
17.10	MDPREBP	Management Data Preamble Bypass: 0 – detect SMI packets with Preamble 1 – detect SMI packets without preamble	RW	0
17.9	FARLOOPBACK	Force the module to the FAR Loop Back mode, i.e. all the received packets are sent back simultaneously (in 100Base-TX only). This bit is only active in RMII mode, as described in Section 5.3.8.2 . This mode works even if MII Isolate (0.10) is set.	RW	0
17.8:7	Reserved	Write as 0, ignore on read.	RW	00

Table 5.29 Register 17 - Mode Control/Status (continued)

ADDRESS	NAME	DESCRIPTION	MODE	DEFAULT
17.6	ALTINT	Alternate Interrupt Mode. 0 = Primary interrupt system enabled (Default). 1 = Alternate interrupt system enabled. See Section 5.2, "Interrupt Management," on page 47 .	RW	0
17.5:4	Reserved	Write as 0, ignore on read.	RW	00
17.3	PHYADBP	1 = PHY disregards PHY address in SMI access write.	RW	0
17.2	Force Good Link Status	0 = normal operation; 1 = force 100TX- link active; Note: This bit should be set only during lab testing	RW	0
17.1	ENERGYON	ENERGYON – indicates whether energy is detected on the line (see Section 5.3.5.2, "Energy Detect Power-Down," on page 50); it goes to "0" if no valid energy is detected within 256ms. Reset to "1" by hardware reset, unaffected by SW reset.	RO	X
17.0	Reserved	Write as 0. Ignore on read.	RW	0

Table 5.30 Register 18 - Special Modes

ADDRESS	NAME	DESCRIPTION	MODE	DEFAULT
18.15	Reserved	Write as 0, ignore on read.	RW	0
18.14	MIIMODE	MII Mode: set the mode of the digital interface, as described in Section 5.3.9.3 : 0 – MII interface. 1 – RMII interface	RW, NASR	X
18.13:8	Reserved	Write as 0, ignore on read.	RW, NASR	000000
18.7:5	MODE	Transceiver Mode of operation. Refer to Section 5.3.9.2, "Mode Bus – MODE[2:0]," on page 53 for more details.	RW, NASR	XXX
18.4:0	PHYAD	PHY Address. The PHY Address is used for the SMI address and for the initialization of the Cipher (Scrambler) key. Refer to Section 5.3.9.1, "Physical Address Bus - PHYAD[2:0]," on page 52 for more details.	RW, NASR	PHYAD

Table 5.31 Register 26 - Symbol Error Counter

ADDRESS	NAME	DESCRIPTION	MODE	DEFAULT
26.15:0	Sym_Err_Cnt	100Base-TX receiver-based error register that increments when an invalid code symbol is received including IDLE symbols. The counter is incremented only once per packet, even when the received packet contains more than one symbol error. The 16-bit register counts up to 65,536 (2^{16}) and rolls over to 0 if incremented beyond that value. This register is cleared on reset, but is not cleared by reading the register. It does not increment in 10Base-T mode.	RO	0



Datasheet

Table 5.32 Register 27 - Special Control/Status Indications

ADDRESS	NAME	DESCRIPTION	MODE	DEFAULT
27.15	AMDIXCTRL	HP Auto-MDIX control 0 - Auto-MDIX enable 1 - Auto-MDIX disabled (use 27.13 to control channel)	RW	0
27.14	Reserved	Reserved	RW	0
27.13	CH_SELECT	Manual Channel Select 0 - MDI -TX transmits RX receives 1 - MDIX -TX receives RX transmits	RW	0
27.12	Reserved	Write as 0. Ignore on read.	RW	0
27:11	SQEOFF	Disable the SQE (Signal Quality Error) test (Heartbeat): 0 - SQE test is enabled. 1 - SQE test is disabled.	RW, NASR	0
27.10:5	Reserved	Write as 0. Ignore on read.	RW	000000
27.4	XPOL	Polarity state of the 10Base-T: 0 - Normal polarity 1 - Reversed polarity	RO	0
27.3:0	Reserved	Reserved	RO	XXXXb

Table 5.33 Register 28 - Special Internal Testability Controls

ADDRESS	NAME	DESCRIPTION	MODE	DEFAULT
28.15:0	Reserved	Do not write to this register. Ignore on read.	RW	N/A

Table 5.34 Register 29 - Interrupt Source Flags

ADDRESS	NAME	DESCRIPTION	MODE	DEFAULT
29.15:8	Reserved	Ignore on read.	RO/ LH	0
29.7	INT7	1 = ENERGYON generated 0 = not source of interrupt	RO/ LH	X
29.6	INT6	1 = Auto-Negotiation complete 0 = not source of interrupt	RO/ LH	X
29.5	INT5	1 = Remote Fault Detected 0 = not source of interrupt	RO/ LH	X
29.4	INT4	1 = Link Down (link status negated) 0 = not source of interrupt	RO/ LH	X
29.3	INT3	1 = Auto-Negotiation LP Acknowledge 0 = not source of interrupt	RO/ LH	X
29.2	INT2	1 = Parallel Detection Fault 0 = not source of interrupt	RO/ LH	X

Table 5.34 Register 29 - Interrupt Source Flags (continued)

ADDRESS	NAME	DESCRIPTION	MODE	DEFAULT
29.1	INT1	1 = Auto-Negotiation Page Received 0 = not source of interrupt	RO/ LH	X
29.0	Reserved	Ignore on read.	RO/ LH	0

Table 5.35 Register 30 - Interrupt Mask

ADDRESS	NAME	DESCRIPTION	MODE	DEFAULT
30.15:8	Reserved	Write as 0; ignore on read.	RO	0
30.7:1	Mask Bits	1 = interrupt source is enabled 0 = interrupt source is masked	RW	0
30.0	Reserved	Write as 0; ignore on read	RO	0

Table 5.36 Register 31 - PHY Special Control/Status

ADDRESS	NAME	DESCRIPTION	MODE	DEFAULT
31.15:13	Reserved	Write as 0, ignore on read.	RW	0
31.12	Autodone	Auto-negotiation done indication: 0 = Auto-negotiation is not done or disabled (or not active) 1 = Auto-negotiation is done Note: This is a duplicate of register 1.5, however reads to register 31 do not clear status bits.	RO	0
31.11:10	Reserved	Write as 0, ignore on Read.	RW	XX
31.9:7	GPO[2:0]	General Purpose Output connected to signals GPO[2:0]	RW	0
31.6	Enable 4B5B	0 = Bypass encoder/decoder. 1 = enable 4B5B encoding/decoding. MAC Interface must be configured in MII mode.	RW	1
31.5	Reserved	Write as 0, ignore on Read.	RW	0
31.4:2	Speed Indication	HCDSPEED value: [001]=10Mbps Half-duplex [101]=10Mbps Full-duplex [010]=100Base-TX Half-duplex [110]=100Base-TX Full-duplex	RO	XXX
31.1	Reserved	Write as 0; ignore on Read	RW	0
31.0	Scramble Disable	0 = enable data scrambling 1 = disable data scrambling,	RW	0



5.2 Interrupt Management

The Management interface supports an interrupt capability that is not a part of the IEEE 802.3 specification. It generates an active low asynchronous interrupt signal on the nINT output whenever certain events are detected as setup by the Interrupt Mask Register 30.

The Interrupt system on the SMSC The LAN8710 has two modes, a Primary Interrupt mode and an Alternative Interrupt mode. Both systems will assert the nINT pin low when the corresponding mask bit is set, the difference is how they de-assert the output interrupt signal nINT.

The Primary interrupt mode is the default interrupt mode after a power-up or hard reset, the Alternative interrupt mode would need to be setup again after a power-up or hard reset.

5.2.1 Primary Interrupt System

The Primary Interrupt system is the default interrupt mode, (Bit 17.6 = '0'). The Primary Interrupt System is always selected after power-up or hard reset.

To set an interrupt, set the corresponding mask bit in the interrupt Mask register 30 (see [Table 5.37](#)). Then when the event to assert nINT is true, the nINT output will be asserted.

When the corresponding Event to De-Assert nINT is true, then the nINT will be de-asserted.

Table 5.37 Interrupt Management Table

MASK	INTERRUPT SOURCE FLAG		INTERRUPT SOURCE		EVENT TO ASSERT nINT	EVENT TO DE-ASSERT nINT
30.7	29.7	ENERGYON	17.1	ENERGYON	Rising 17.1 (Note 5.1)	Falling 17.1 or Reading register 29
30.6	29.6	Auto-Negotiation complete	1.5	Auto-Negotiate Complete	Rising 1.5	Falling 1.5 or Reading register 29
30.5	29.5	Remote Fault Detected	1.4	Remote Fault	Rising 1.4	Falling 1.4, or Reading register 1 or Reading register 29
30.4	29.4	Link Down	1.2	Link Status	Falling 1.2	Reading register 1 or Reading register 29
30.3	29.3	Auto-Negotiation LP Acknowledge	5.14	Acknowledge	Rising 5.14	Falling 5.14 or Read register 29
30.2	29.2	Parallel Detection Fault	6.4	Parallel Detection Fault	Rising 6.4	Falling 6.4 or Reading register 6, or Reading register 29 or Re-Auto Negotiate or Link down
30.1	29.1	Auto-Negotiation Page Received	6.1	Page Received	Rising 6.1	Falling of 6.1 or Reading register 6, or Reading register 29 Re-Auto Negotiate, or Link Down.

Note 5.1 If the mask bit is enabled and nINT has been de-asserted while ENERGYON is still high, nINT will assert for 256 ms, approximately one second after ENERGYON goes low when the Cable is unplugged. To prevent an unexpected assertion of nINT, the ENERGYON interrupt mask should always be cleared as part of the ENERGYON interrupt service routine.

Note: The ENERGYON bit 17.1 is defaulted to a '1' at the start of the signal acquisition process, therefore the Interrupt source flag 29.7 will also read as a '1' at power-up. If no signal is present, then both 17.1 and 29.7 will clear within a few milliseconds.

5.2.2 Alternate Interrupt System

The Alternative method is enabled by writing a '1' to 17.6 (ALTINT).

To set an interrupt, set the corresponding bit of the in the Mask Register 30, (see [Table 5.38](#)).

To Clear an interrupt, either clear the corresponding bit in the Mask Register (30), this will de-assert the nINT output, or Clear the Interrupt Source, and write a '1' to the corresponding Interrupt Source Flag. Writing a '1' to the Interrupt Source Flag will cause the state machine to check the Interrupt Source to determine if the Interrupt Source Flag should clear or stay as a '1'. If the Condition to De-Assert is true, then the Interrupt Source Flag is cleared, and the nINT is also de-asserted. If the Condition to De-Assert is false, then the Interrupt Source Flag remains set, and the nINT remains asserted.

For example 30.7 is set to '1' to enable the ENERGYON interrupt. After a cable is plugged in, ENERGYON (17.1) goes active and nINT will be asserted low.

To de-assert the nINT interrupt output, either.

1. Clear the ENERGYON bit (17.1), by removing the cable, then writing a '1' to register 29.7.
- Or
2. Clear the Mask bit 30.1 by writing a '0' to 30.1.

Table 5.38 Alternative Interrupt System Management Table

MASK	INTERRUPT SOURCE FLAG		INTERRUPT SOURCE		EVENT TO ASSERT nINT	CONDITION TO DE-ASSERT	BIT TO CLEAR nINT
30.7	29.7	ENERGYON	17.1	ENERGYON	Rising 17.1	17.1 low	29.7
30.6	29.6	Auto-Negotiation complete	1.5	Auto-Negotiate Complete	Rising 1.5	1.5 low	29.6
30.5	29.5	Remote Fault Detected	1.4	Remote Fault	Rising 1.4	1.4 low	29.5
30.4	29.4	Link Down	1.2	Link Status	Falling 1.2	1.2 high	29.4
30.3	29.3	Auto-Negotiation LP Acknowledge	5.14	Acknowledge	Rising 5.14	5.14 low	29.3
30.2	29.2	Parallel Detection Fault	6.4	Parallel Detection Fault	Rising 6.4	6.4 low	29.2
30.1	29.1	Auto-Negotiation Page Received	6.1	Page Received	Rising 6.1	6.1 low	29.1

Note: The ENERGYON bit 17.1 is defaulted to a '1' at the start of the signal acquisition process, therefore the Interrupt source flag 29.7 will also read as a '1' at power-up. If no signal is present, then both 17.1 and 29.7 will clear within a few milliseconds.

5.3 Miscellaneous Functions

5.3.1 Carrier Sense

The carrier sense is output on CRS. CRS is a signal defined by the MII specification in the IEEE 802.3u standard. The LAN8710 asserts CRS based only on receive activity whenever the transceiver is either



Datasheet

in repeater mode or full-duplex mode. Otherwise the transceiver asserts CRS based on either transmit or receive activity.

The carrier sense logic uses the encoded, unscrambled data to determine carrier activity status. It activates carrier sense with the detection of 2 non-contiguous zeros within any 10 bit span. Carrier sense terminates if a span of 10 consecutive ones is detected before a /J/K/ Start-of Stream Delimiter pair. If an SSD pair is detected, carrier sense is asserted until either /T/R/ End-of-Stream Delimiter pair or a pair of IDLE symbols is detected. Carrier is negated after the /T/ symbol or the first IDLE. If /T/ is not followed by /R/, then carrier is maintained. Carrier is treated similarly for IDLE followed by some non-IDLE symbol.

5.3.2 Collision Detect

A collision is the occurrence of simultaneous transmit and receive operations. The COL output is asserted to indicate that a collision has been detected. COL remains active for the duration of the collision. COL is changed asynchronously to both RXCLK and TXCLK. The COL output becomes inactive during full duplex mode.

COL may be tested by setting register 0, bit 7 high. This enables the collision test. COL will be asserted within 512 bit times of TXEN rising and will be de-asserted within 4 bit times of TXEN falling.

In 10M mode, COL pulses for approximately 10 bit times (1us), 2us after each transmitted packet (de-assertion of TXEN). This is the Signal Quality Error (SQE) signal and indicates that the transmission was successful. The user can disable this pulse by setting bit 11 in register 27.

5.3.3 Isolate Mode

The LAN8710 data paths may be electrically isolated from the MII by setting register 0, bit 10 to a logic one. In isolation mode, the transceiver does not respond to the TXD, TXEN and TXER inputs, but does respond to management transactions.

Isolation provides a means for multiple transceivers to be connected to the same MII without contention occurring. The transceiver is not isolated on power-up (bit 0:10 = 0).

5.3.4 Link Integrity Test

The LAN8710 performs the link integrity test as outlined in the IEEE 802.3u (Clause 24-15) Link Monitor state diagram. The link status is multiplexed with the 10Mbps link status to form the reportable link status bit in Serial Management Register 1, and is driven to the LINK LED.

The DSP indicates a valid MLT-3 waveform present on the RXP and RXN signals as defined by the ANSI X3.263 TP-PMD standard, to the Link Monitor state-machine, using internal signal called DATA_VALID. When DATA_VALID is asserted the control logic moves into a Link-Ready state, and waits for an enable from the Auto Negotiation block. When received, the Link-Up state is entered, and the Transmit and Receive logic blocks become active. Should Auto Negotiation be disabled, the link integrity logic moves immediately to the Link-Up state, when the DATA_VALID is asserted.

Note that to allow the line to stabilize, the link integrity logic will wait a minimum of 330 μsec from the time DATA_VALID is asserted until the Link-Ready state is entered. Should the DATA_VALID input be negated at any time, this logic will immediately negate the Link signal and enter the Link-Down state.

When the 10/100 digital block is in 10Base-T mode, the link status is from the 10Base-T receiver logic.

5.3.5 Power-Down modes

There are 2 power-down modes for the LAN8710 described in the following sections.

5.3.5.1 General Power-Down

This power-down is controlled by register 0, bit 11. In this mode the entire transceiver, except the management interface, is powered-down and stays in that condition as long as bit 0.11 is HIGH. When bit 0.11 is cleared, the transceiver powers up and is automatically reset.

5.3.5.2 Energy Detect Power-Down

This power-down mode is activated by setting bit 17.13 to 1. In this mode when no energy is present on the line the transceiver is powered down, except for the management interface, the SQUELCH circuit and the ENERGYON logic. The ENERGYON logic is used to detect the presence of valid energy from 100Base-TX, 10Base-T, or Auto-negotiation signals

In this mode, when the ENERGYON signal is low, the transceiver is powered-down, and nothing is transmitted. When energy is received - link pulses or packets - the ENERGYON signal goes high, and the transceiver powers-up. It automatically resets itself into the state it had prior to power-down, and asserts the nINT interrupt if the ENERGYON interrupt is enabled. The first and possibly the second packet to activate ENERGYON may be lost.

When 17.13 is low, energy detect power-down is disabled.

5.3.6 Reset

The LAN8710 registers are reset by the Hardware and Software resets. Some SMI register bits are not cleared by Software reset, and these are marked "NASR" in the register tables. The SMI registers are not reset by the power-down modes described in [Section 5.3.5](#).

For the first 16us after coming out of reset, the MII will run at 2.5 MHz. After that it will switch to 25 MHz if auto-negotiation is enabled.

5.3.6.1 Hardware Reset

Hardware reset is asserted by driving the nRST input low.

When the nRST input is driven by an external source, it should be held LOW for at least 100 us to ensure that the transceiver is properly reset. During a hardware reset an external clock **must** be supplied to the XTAL1/CLKIN signal.

5.3.6.2 Software Reset

Software reset is activated by writing register 0, bit 15 high. This signal is self-clearing. The SMI registers are reset except those that are marked "NASR" in the register tables.

The IEEE 802.3u standard, clause 22 (22.2.4.1.1) states that the reset process should be completed within 0.5s from the setting of this bit.

5.3.7 LED Description

The LAN8710 provides two LED signals. These provide a convenient means to determine the mode of operation of the transceiver. All LED signals are either active high or active low as described in [Section 4.10](#) and [Section 4.11](#).

The LED1 output is driven active whenever the LAN8710 detects a valid link, and blinks when CRS is active (high) indicating activity.

The LED2 output is driven active when the operating speed is 100Mbit/s. This LED will go inactive when the operating speed is 10Mbit/s or during line isolation (register 31 bit 5).

5.3.8 Loopback Operation

The LAN8710 may be configured for near-end loopback and far loopback.

Datasheet

5.3.8.1 Near-end Loopback

Near-end loopback is a mode that sends the digital transmit data back out the receive data signals for testing purposes as indicated by the blue arrows in Figure 5.1. The near-end loopback mode is enabled by setting bit register 0 bit 14 to logic one.

A large percentage of the digital circuitry is operational near-end loopback mode, because data is routed through the PCS and PMA layers into the PMD sublayer before it is looped back. The COL signal will be inactive in this mode, unless collision test (bit 0.7) is active. The transmitters are powered down, regardless of the state of TXEN.

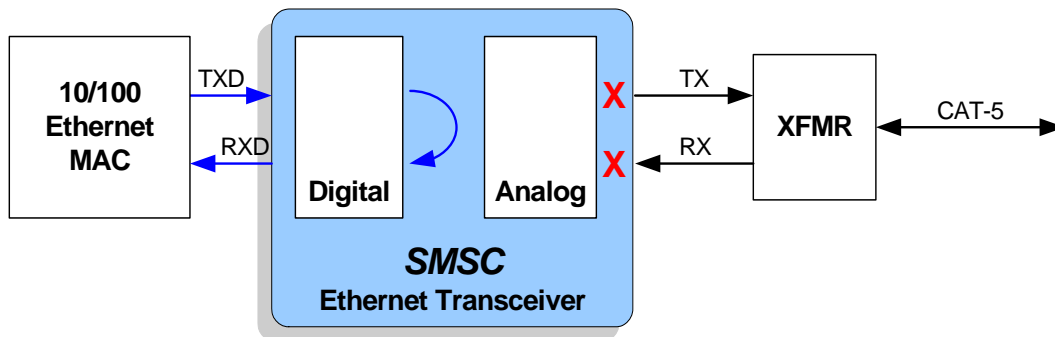

Figure 5.1 Near-end Loopback Block Diagram

5.3.8.2 Far Loopback

This special test mode is only available when operating in RMII mode. When the the RXD2/RMIISEL pin is configured for MII mode, the SMI can be used to override this setting as described in Section 5.3.9.3.

Far loopback is a special test mode for MDI (analog) loopback as indicated by the blue arrows in Figure 5.3. The far loopback mode is enabled by setting bit register 17 bit 9 to logic one. In this mode, data that is received from the link partner on the MDI is looped back out to the link partner. The digital interface signals on the local MAC interface are isolated.

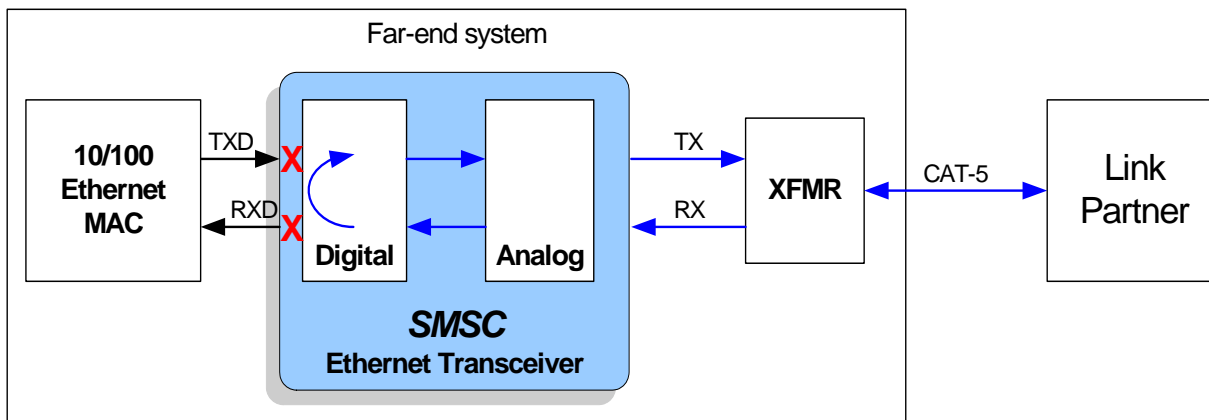

Figure 5.2 Far Loopback Block Diagram

5.3.8.3 Connector Loopback

The LAN8710/LAN8710i maintains reliable transmission over very short cables, and can be tested in a connector loopback as shown in Figure 5.3. An RJ45 loopback cable can be used to route the transmit signals an the output of the transformer back to the receiver inputs, and this loopback will work at both 10 and 100.

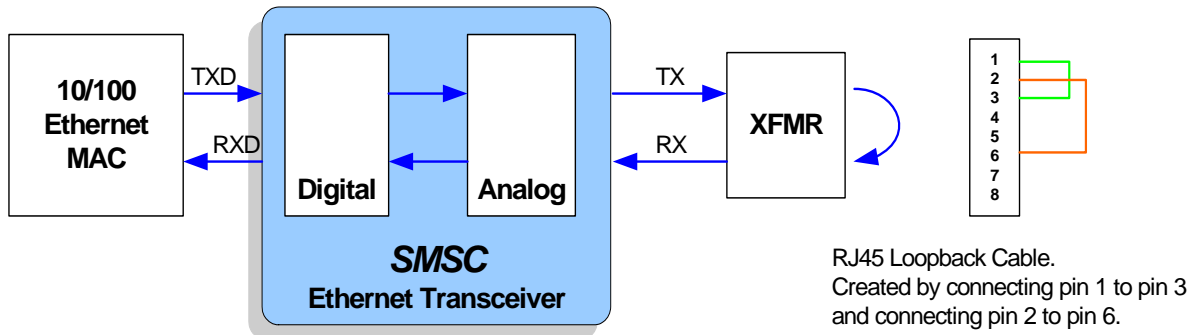

Figure 5.3 Connector Loopback Block Diagram

5.3.9 Configuration Signals

The hardware configuration signals are sampled during the power-on sequence to determine the physical address and operating mode.

5.3.9.1 Physical Address Bus - PHYAD[2:0]

The PHYAD[2:0] bits are driven high or low to give each PHY a unique address. This address is latched into an internal register at the end of a hardware reset. In a multi-transceiver application (such as a repeater), the controller is able to manage each transceiver via the unique address. Each transceiver checks each management data frame for a matching address in the relevant bits. When a match is recognized, the transceiver responds to that particular frame. The PHY address is also used to seed the scrambler. In a multi-Transceiver application, this ensures that the scramblers are out of synchronization and disperses the electromagnetic radiation across the frequency spectrum.

The LAN8710 SMI address may be configured using hardware configuration to any value between 0 and 7. The user can configure the PHY address using Software Configuration if an address greater than 7 is required. The PHY address can be written (after SMI communication at some address is established) using the 10/100 Special Modes register (bits18.[4:0]).

The PHYAD[2:0] hardware configuration pins are multiplexed with other signals as shown in Table 5.39.

Table 5.39 Pin Names for Address Bits

ADDRESS BIT	PIN NAME
PHYAD[0]	RXER/PHYAD0
PHYAD[1]	RXCLK/PHYAD1
PHYAD[2]	RXD3/PHYAD2

The LAN8710 may be configured to disregard the PHY address in SMI access write by setting the register bit 17.3 (PHYADBP).

Datasheet

5.3.9.2 Mode Bus – MODE[2:0]

The MODE[2:0] bus controls the configuration of the 10/100 digital block. When the nRST pin is deasserted, the register bit values are loaded according to the MODE[2:0] pins. The 10/100 digital block is then configured by the register bit values. When a soft reset occurs (bit 0.15) as described in [Table 5.21](#), the configuration of the 10/100 digital block is controlled by the register bit values, and the MODE[2:0] pins have no affect.

The LAN8710 mode may be configured using hardware configuration as summarized in [Table 5.40](#). The user may configure the transceiver mode by writing the SMI registers.

Table 5.40 MODE[2:0] Bus

MODE[2:0]	MODE DEFINITIONS	DEFAULT REGISTER BIT VALUES	
		REGISTER 0	REGISTER 4
		[13,12,10,8]	[8,7,6,5]
000	10Base-T Half Duplex. Auto-negotiation disabled.	0000	N/A
001	10Base-T Full Duplex. Auto-negotiation disabled.	0001	N/A
010	100Base-TX Half Duplex. Auto-negotiation disabled. CRS is active during Transmit & Receive.	1000	N/A
011	100Base-TX Full Duplex. Auto-negotiation disabled. CRS is active during Receive.	1001	N/A
100	100Base-TX Half Duplex is advertised. Auto-negotiation enabled. CRS is active during Transmit & Receive.	1100	0100
101	Repeater mode. Auto-negotiation enabled. 100Base-TX Half Duplex is advertised. CRS is active during Receive.	1100	0100
110	Power Down mode. In this mode the transceiver will wake-up in Power-Down mode. The transceiver cannot be used when the MODE[2:0] bits are set to this mode. To exit this mode, the MODE bits in Register 18.7:5(see Table 5.30) must be configured to some other value and a soft reset must be issued.	N/A	N/A
111	All capable. Auto-negotiation enabled.	X10X	1111

The MODE[2:0] hardware configuration pins are multiplexed with other signals as shown in [Table 5.41](#).

Table 5.41 Pin Names for Mode Bits

MODE BIT	PIN NAME
MODE[0]	RXD0/MODE0
MODE[1]	RXD1/MODE1
MODE[2]	COL/CRS_DV/MODE2

5.3.9.3 MII/RMII Mode Selection

MII or RMII mode selection is latched on the rising edge of the internal reset (nRESET) based on the strapping of the RXD2/RMIISEL pin. The default mode is MII with the internal pull-down resistor. To select RMII mode, pull the RXD2/RMIISEL pin high with an external resistor to VDDIO.

When the nRST pin is deasserted, the register bit 18.14 (MIIMODE) is loaded according to the RXD2/RMIISEL pin. The mode is then configured by the register bit value. When a soft reset occurs (bit 0.15) as described in [Table 5.21](#), the MII or RMII mode selection is controlled by the register bit 18.14, and the RXD2/RMIISEL pin has no affect.

Chapter 6 AC Electrical Characteristics

The timing diagrams and limits in this section define the requirements placed on the external signals of the Phy.

6.1 Serial Management Interface (SMI) Timing

The Serial Management Interface is used for status and control as described in [Section 4.14](#).

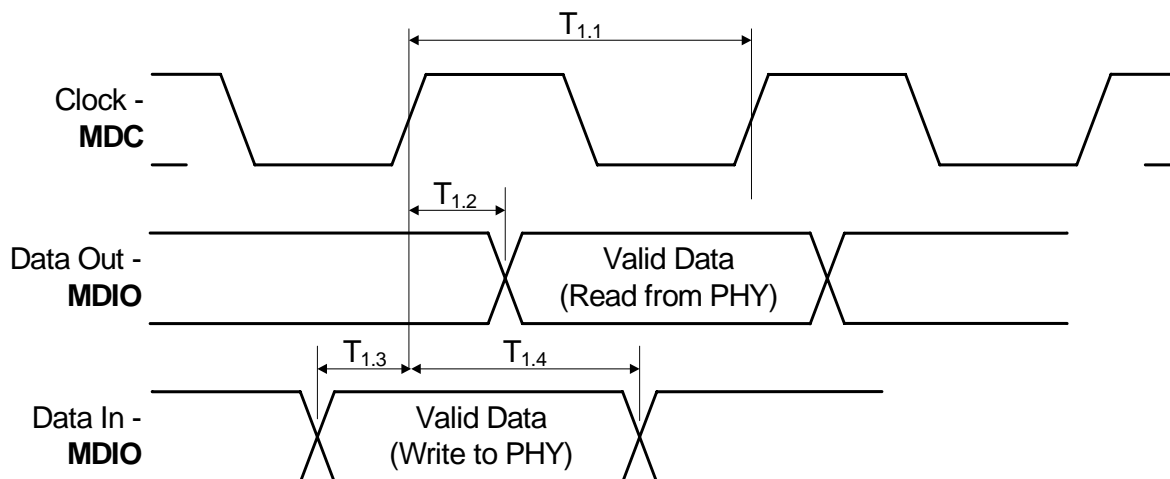

Figure 6.1 SMI Timing Diagram

Table 6.1 SMI Timing Values

PARAMETER	DESCRIPTION	MIN	TYP	MAX	UNITS	NOTES
T1.1	MDC minimum cycle time	400			ns	
T1.2	MDC to MDIO (Read from PHY) delay	0		30	ns	
T1.3	MDIO (Write to PHY) to MDC setup	10			ns	
T1.4	MDIO (Write to PHY) to MDC hold	10			ns	

6.2 MII 10/100Base-TX/RX Timings

6.2.1 MII 100Base-T TX/RX Timings

6.2.1.1 100M MII Receive Timing

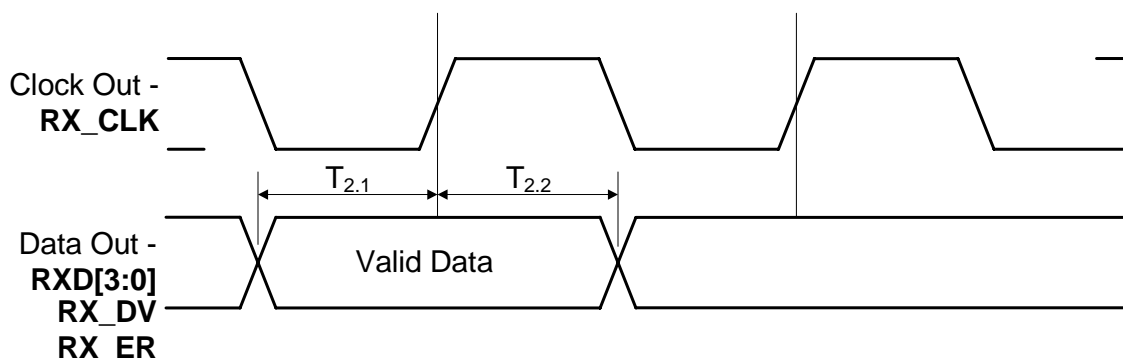

Figure 6.2 100M MII Receive Timing Diagram

Table 6.2 100M MII Receive Timing Values

PARAMETER	DESCRIPTION	MIN	TYP	MAX	UNITS	NOTES
T2.1	Receive signals setup to RXCLK rising	10			ns	
T2.2	Receive signals hold from RXCLK rising	10			ns	
	RXCLK frequency		25		MHz	
	RXCLK Duty-Cycle		50		%	

Datasheet

6.2.1.2 100M MII Transmit Timing

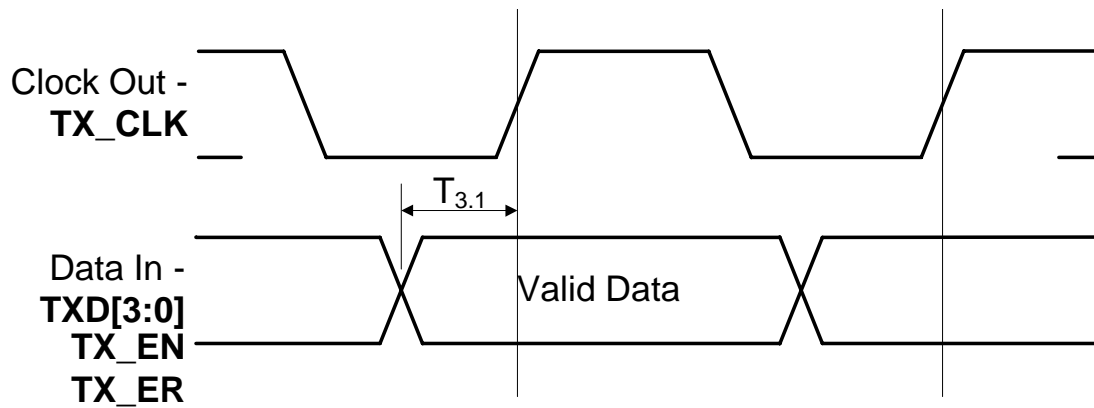

Figure 6.3 100M MII Transmit Timing Diagram

Table 6.3 100M MII Transmit Timing Values

PARAMETER	DESCRIPTION	MIN	TYP	MAX	UNITS	NOTES
T3.1	Transmit signals required setup to TXCLK rising	12			ns	
	Transmit signals required hold after TXCLK rising	0			ns	
	TXCLK frequency		25		MHz	
	TXCLK Duty-Cycle		50		%	

6.2.2 MII 10Base-T TX/RX Timings

6.2.2.1 10M MII Receive Timing

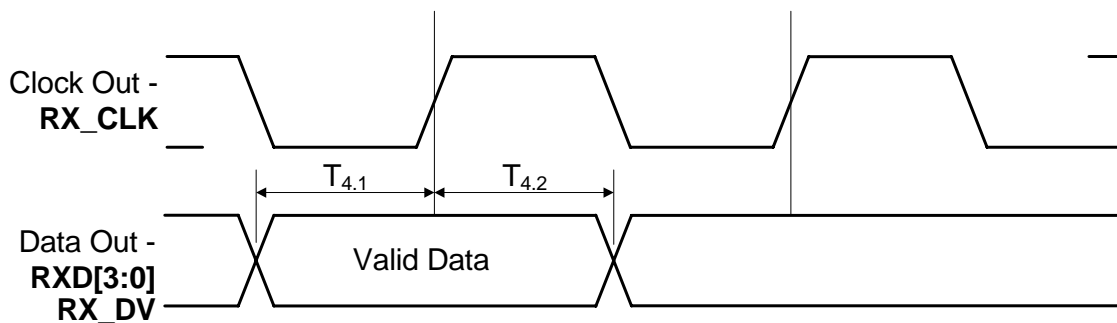

Figure 6.4 10M MII Receive Timing Diagram

Table 6.4 10M MII Receive Timing Values

PARAMETER	DESCRIPTION	MIN	TYP	MAX	UNITS	NOTES
T4.1	Receive signals setup to RXCLK rising	10			ns	
T4.2	Receive signals hold from RXCLK rising	10			ns	
	RXCLK frequency		2.5		MHz	
	RXCLK Duty-Cycle		50		%	

Datasheet

6.2.2.2 10M MII Transmit Timing

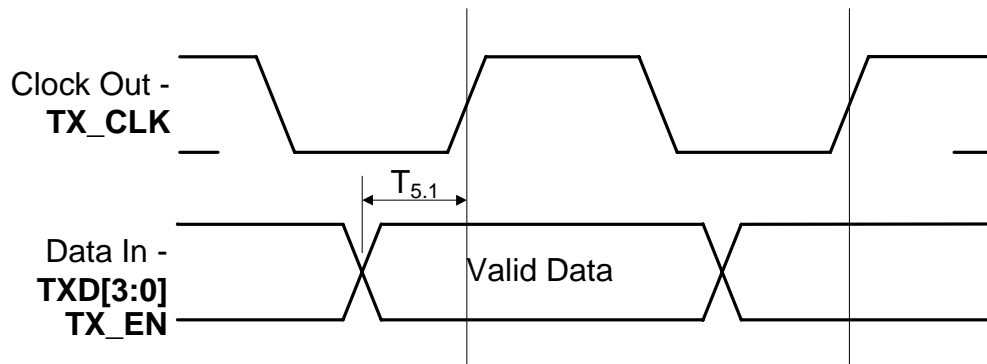

Figure 6.5 10M MII Transmit Timing Diagrams

Table 6.5 10M MII Transmit Timing Values

PARAMETER	DESCRIPTION	MIN	TYP	MAX	UNITS	NOTES
T5.1	Transmit signals required setup to TXCLK rising	12			ns	
	Transmit signals required hold after TXCLK rising	0			ns	
	TXCLK frequency		2.5		MHz	
	TXCLK Duty-Cycle		50		%	

6.3 RMII 10/100Base-TX/RX Timings (50MHz REF_CLK IN)

6.3.1 RMII 100Base-T TX/RX Timings (50MHz REF_CLK IN)

6.3.1.1 100M RMII Receive Timing (50MHz REF_CLK IN)

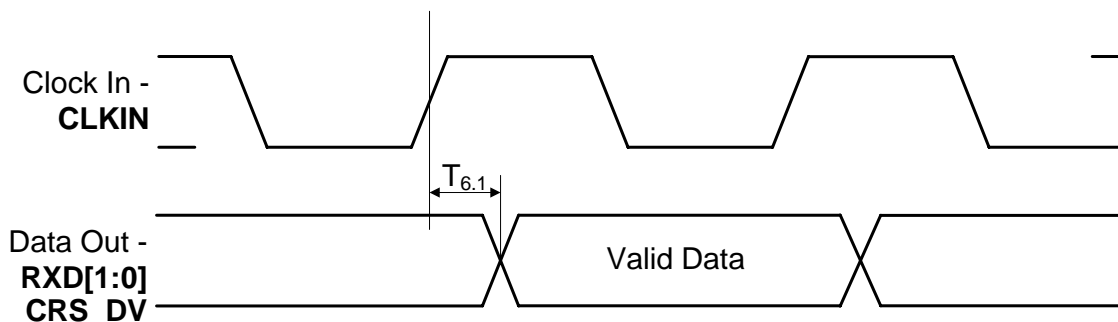

Figure 6.6 100M RMII Receive Timing Diagram (50MHz REF_CLK IN)

Table 6.6 100M RMII Receive Timing Values (50MHz REF_CLK IN)

PARAMETER	DESCRIPTION	MIN	TYP	MAX	UNITS	NOTES
T6.1	Output delay from rising edge of CLKIN to receive signals output valid	3		10	ns	
	CLKIN frequency		50		MHz	



Datasheet

6.3.1.2 100M RMII Transmit Timing (50MHz REF_CLK IN)

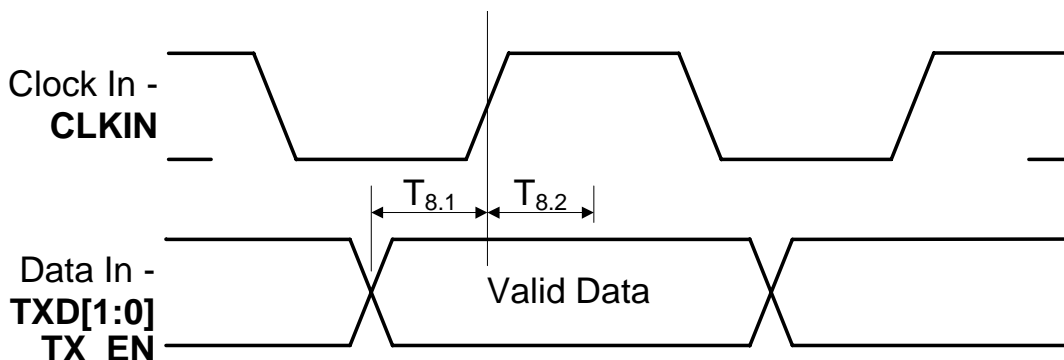

Figure 6.7 100M RMII Transmit Timing Diagram (50MHz REF_CLK IN)

Table 6.7 100M RMII Transmit Timing Values (50MHz REF_CLK IN)

PARAMETER	DESCRIPTION	MIN	TYP	MAX	UNITS	NOTES
T8.1	Transmit signals required setup to rising edge of CLKIN	4			ns	
T8.2	Transmit signals required hold after rising edge of CLKIN	2			ns	
	CLKIN frequency		50		MHz	

6.3.2 RMII 10Base-T TX/RX Timings (50MHz REF_CLK IN)

6.3.2.1 10M RMII Receive Timing (50MHz REF_CLK IN)

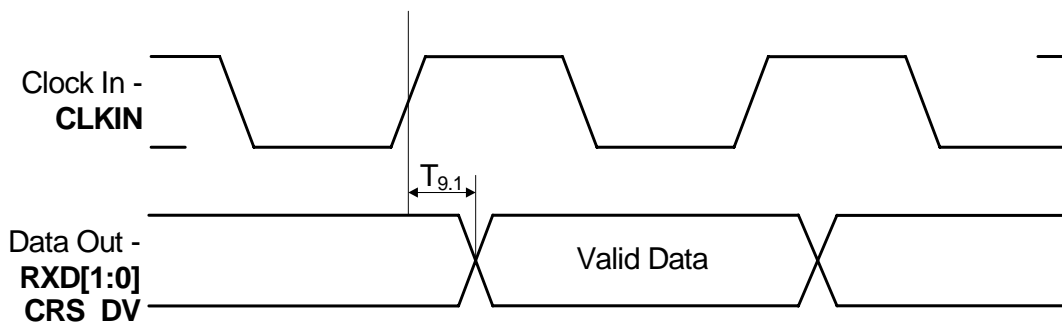

Figure 6.8 10M RMII Receive Timing Diagram (50MHz REF_CLK IN)

Table 6.8 10M RMII Receive Timing Values (50MHz REF_CLK IN)

PARAMETER	DESCRIPTION	MIN	TYP	MAX	UNITS	NOTES
T9.1	Output delay from rising edge of CLKIN to receive signals output valid	3		10	ns	
	CLKIN frequency		50		MHz	



Datasheet

6.3.2.2 10M RMII Transmit Timing (50MHz REF_CLK IN)

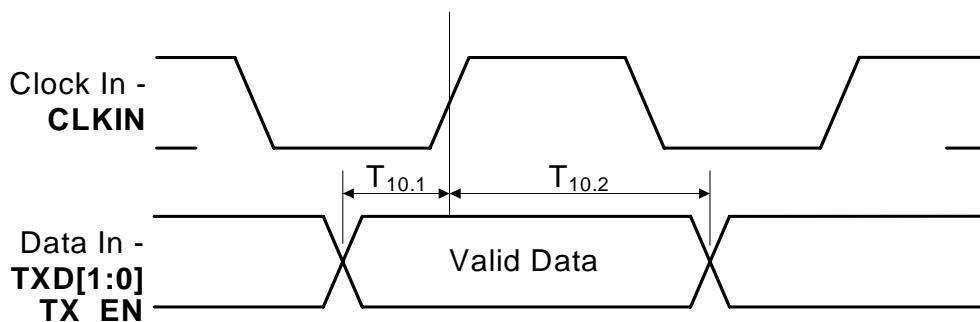

Figure 6.9 10M RMII Transmit Timing Diagram (50MHz REF_CLK IN)

Table 6.9 10M RMII Transmit Timing Values (50MHz REF_CLK IN)

PARAMETER	DESCRIPTION	MIN	TYP	MAX	UNITS	NOTES
T10.1	Transmit signals required setup to rising edge of CLKIN	4			ns	
T10.2	Transmit signals required hold after rising edge of CLKIN	2			ns	
	CLKIN frequency		50		MHz	

6.4 RMII CLKIN Requirements

Table 6.10 RMII CLKIN (REF_CLK) Timing Values

PARAMETER	DESCRIPTION	MIN	TYP	MAX	UNITS	NOTES
	CLKIN frequency		50		MHz	
	CLKIN Frequency Drift			± 50	ppm	
	CLKIN Duty Cycle	40		60	%	
	CLKIN Jitter			150	psec	p-p – not RMS

6.5 Reset Timing

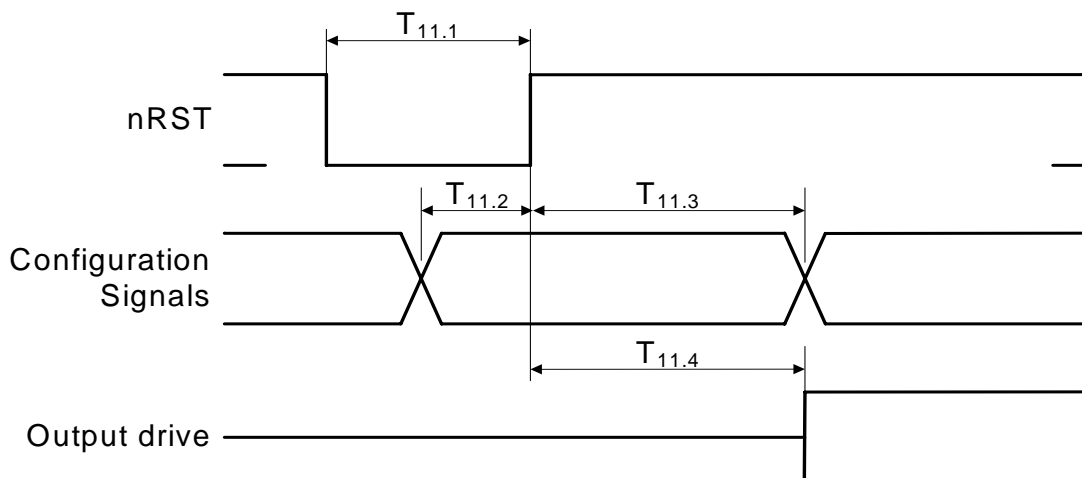
Figure 6.10 Reset Timing Diagram
Table 6.11 Reset Timing Values

PARAMETER	DESCRIPTION	MIN	TYP	MAX	UNITS	NOTES
T11.1	Reset Pulse Width	100			us	
T11.2	Configuration input setup to nRST rising	200			ns	
T11.3	Configuration input hold after nRST rising	10			ns	
T11.4	Output Drive after nRST rising	20		800	ns	20 clock cycles for 25 MHz clock or 40 clock cycles for 50MHz clock



Datasheet

6.6 Clock Circuit

LAN8710/LAN8710i can accept either a 25MHz crystal or a 25MHz single-ended clock oscillator (± 50 ppm) input. If the single-ended clock oscillator method is implemented, XTAL2 should be left unconnected and XTAL1/CLKIN should be driven with a nominal 0-3.3V clock signal. See [Table 6.12](#) for the recommended crystal specifications.

Table 6.12 LAN8710/LAN8710i Crystal Specifications

PARAMETER	SYMBOL	MIN	NOM	MAX	UNITS	NOTES
Crystal Cut		AT, typ				
Crystal Oscillation Mode		Fundamental Mode				
Crystal Calibration Mode		Parallel Resonant Mode				
Frequency	F_{fund}	-	25.000	-	MHz	
Frequency Tolerance @ 25°C	F_{tol}	-	-	± 50	PPM	Note 6.1
Frequency Stability Over Temp	F_{temp}	-	-	± 50	PPM	Note 6.1
Frequency Deviation Over Time	F_{age}	-	+/-3 to 5	-	PPM	Note 6.2
Total Allowable PPM Budget		-	-	± 50	PPM	Note 6.3
Shunt Capacitance	C_O	-	7 typ	-	pF	
Load Capacitance	C_L	-	20 typ	-	pF	
Drive Level	P_W	300	-	-	uW	
Equivalent Series Resistance	R_1	-	-	30	Ohm	
Operating Temperature Range		Note 6.4	-	Note 6.5	°C	
LAN8710/LAN8710i XTAL1/CLKIN Pin Capacitance		-	3 typ	-	pF	Note 6.6
LAN8710/LAN8710i XTAL2 Pin Capacitance		-	3 typ	-	pF	Note 6.6

Note 6.1 The maximum allowable values for Frequency Tolerance and Frequency Stability are application dependant. Since any particular application must meet the IEEE ± 50 PPM Total PPM Budget, the combination of these two values must be approximately ± 45 PPM (allowing for aging).

Note 6.2 Frequency Deviation Over Time is also referred to as Aging.

Note 6.3 The total deviation for the Transmitter Clock Frequency is specified by IEEE 802.3u as ± 100 PPM.

Note 6.4 0°C for extended commercial version, -40°C for industrial version.

Note 6.5 +85°C for extended commercial version, +85°C for industrial version.

Note 6.6 This number includes the pad, the bond wire and the lead frame. PCB capacitance is not included in this value. The XTAL1/CLKIN pin, XTAL2 pin and PCB capacitance values are required to accurately calculate the value of the two external load capacitors. The total load capacitance must be equivalent to what the crystal expects to see in the circuit so that the crystal oscillator will operate at 25.000 MHz.

Chapter 7 DC Electrical Characteristics

7.1 DC Characteristics

7.1.1 Maximum Guaranteed Ratings

Stresses beyond those listed in may cause permanent damage to the device. Exposure to absolute maximum rating conditions for extended periods may affect device reliability.

Table 7.1 Maximum Conditions

PARAMETER	CONDITIONS	MIN	TYP	MAX	UNITS	COMMENT
VDD1A, VDD2A, VDDIO	Power pins to all other pins.	-0.5		+3.6	V	
Digital IO	To VSS ground	-0.5		+3.6	V	Table 7.5, "MII Bus Interface Signals," on page 69
VSS	VSS to all other pins	-0.5		+0.5	V	
Junction to Ambient (θ_{JA})	Thermal vias per Layout Guidelines.			48.3		°C/W
Junction to Case (θ_{JC})				10.6		°C/W
Operating Temperature	LAN8710-AEZG	0		+85	°C	Extended commercial temperature components.
Operating Temperature	LAN8710i-AEZG	-40		+85	°C	Industrial temperature components.
Storage Temperature		-55		+150	°C	

Table 7.2 ESD and LATCH-UP Performance

PARAMETER	CONDITIONS	MIN	TYP	MAX	UNITS	COMMENTS
ESD PERFORMANCE						
All Pins	Human Body Model			±5	kV	Device
System	IED61000-4-2 Contact Discharge			±15	kV	3rd party system test
System	IEC61000-4-2 Air-gap Discharge			±15	kV	3rd party system test
LATCH-UP PERFORMANCE						
All Pins	EIA/JESD 78, Class II		150		mA	

Datasheet

7.1.1.1 Human Body Model (HBM) Performance

HBM testing verifies the ability to withstand the ESD strikes like those that occur during handling and manufacturing, and is done without power applied to the IC. To pass the test, the device must have no change in operation or performance due to the event. All pins on the LAN8710 provide +/-5kV HBM protection.

7.1.1.2 IEC61000-4-2 Performance

The IEC61000-4-2 ESD specification is an international standard that addresses system-level immunity to ESD strikes while the end equipment is operational. In contrast, the HBM ESD tests are performed at the device level with the device powered down.

SMSC contracts with Independent laboratories to test the LAN8710 to IEC61000-4-2 in a working system. Reports are available upon request. Please contact your SMSC representative, and request information on 3rd party ESD test results. The reports show that systems designed with the LAN8710 can safely dissipate $\pm 15\text{kV}$ air discharges and $\pm 15\text{kV}$ contact discharges per the IEC61000-4-2 specification without additional board level protection.

In addition to defining the ESD tests, IEC 61000-4-2 also categorizes the impact to equipment operation when the strike occurs (ESD Result Classification). The LAN8710 maintains an ESD Result Classification 1 or 2 when subjected to an IEC 61000-4-2 (level 4) ESD strike.

Both air discharge and contact discharge test techniques for applying stress conditions are defined by the IEC61000-4-2 ESD document.

AIR DISCHARGE

To perform this test, a charged electrode is moved close to the system being tested until a spark is generated. This test is difficult to reproduce because the discharge is influenced by such factors as humidity, the speed of approach of the electrode, and construction of the test equipment.

CONTACT DISCHARGE

The uncharged electrode first contacts the pin to prepare this test, and then the probe tip is energized. This yields more repeatable results, and is the preferred test method. The independent test laboratories contracted by SMSC provide test results for both types of discharge methods.

7.1.2 Operating Conditions

Table 7.3 Recommended Operating Conditions

PARAMETER	CONDITIONS	MIN	TYP	MAX	UNITS	COMMENT
VDD1A, VDD2A	To VSS ground	3.0	3.3	3.6	V	
VDDIO	To VSS ground	1.6	3.3	3.6	V	
Input Voltage on Digital Pins		0.0		VDDIO	V	
Voltage on Analog I/O pins (RXP, RXN)		0.0		+3.6V	V	
Ambient Temperature	T _A LAN8710-AEZG	0		+85	°C	For Extended Commercial Temperature
	T _A LAN8710i-AEZG	-40		+85	°C	For Industrial Temperature

7.1.3 Power Consumption

7.1.3.1 Power Consumption Device Only

Power measurements taken over the operating conditions specified. See [Section 5.3.5](#) for a description of the power down modes.

Table 7.4 Power Consumption Device Only

POWER PIN GROUP		VDDA3.3 POWER PINS(MA)	VDDCR POWER PIN(MA)	VDDIO POWER PIN(MA)	TOTAL CURRENT (MA)	TOTAL POWER (MW)
100BASE-T /W TRAFFIC	Max	27.7	20.2	5.2	53.1	175.2
	Typical	25.5	18	4.3	47.8	157.7
	Min	22.7	17.5	2.4	42.6	100.2 Note 7.1
10BASE-T /W TRAFFIC	Max	10.2	12.9	0.98	24.1	79.5
	Typical	9.4	11.4	0.4	21.2	70
	Min	9.2	10.9	0.3	20.4	44 Note 7.1
ENERGY DETECT POWER DOWN	Max	4.5	3	0.3	7.8	25.
	Typical	4.3	1.4	0.2	5.9	19.5
	Min	3.9	1.3	0	5.2	15.9 Note 7.1
GENERAL POWER DOWN	Max	0.4	2.6	0.3	3.3	10.9
	Typical	0.3	1.2	0.2	1.7	5.6
	Min	0.3	1.1	0	1.4	2.4 Note 7.1

Note: The current at VDDCR is either supplied by the internal regulator from current entering at VDD2A, or from an external 1.2V supply when the internal regulator is disabled.

Note 7.1 This is calculated with full flexPWR features activated: VDDIO = 1.8V and internal regulator disabled.

Note 7.2 Current measurements do not include power applied to the magnetics or the optional external LEDs.

Datasheet

7.1.4 DC Characteristics - Input and Output Buffers

Table 7.5 MII Bus Interface Signals

NAME	V _{IH} (V)	V _{IL} (V)	I _{OH}	I _{OL}	V _{OL} (V)	V _{OH} (V)
TXD0	0.63 * VDDIO	0.39 * VDDIO				
TXD1	0.63 * VDDIO	0.39 * VDDIO				
TXD2	0.63 * VDDIO	0.39 * VDDIO				
TXD3	0.63 * VDDIO	0.39 * VDDIO				
TXEN	0.63 * VDDIO	0.39 * VDDIO				
TXCLK			-8 mA	+8 mA	+0.4	VDDIO – +0.4
RXD0/MODE0			-8 mA	+8 mA	+0.4	VDDIO – +0.4
RXD1/MODE1			-8 mA	+8 mA	+0.4	VDDIO – +0.4
RXD2/RMIISEL			-8 mA	+8 mA	+0.4	VDDIO – +0.4
RXD3/PHYAD2			-8 mA	+8 mA	+0.4	VDDIO – +0.4
RXER/RXD4/PHYAD0			-8 mA	+8 mA	+0.4	VDDIO – +0.4
RXDV			-8 mA	+8 mA	+0.4	VDDIO – +0.4
RXCLK/PHYAD1			-8 mA	+8 mA	+0.4	VDDIO – +0.4
CRS			-8 mA	+8 mA	+0.4	VDDIO – +0.4
COL/CRS_DV/MODE2			-8 mA	+8 mA	+0.4	VDDIO – +0.4
MDC	0.63 * VDDIO	0.39 * VDDIO				
MDIO	0.63 * VDDIO	0.39 * VDDIO	-8 mA	+8 mA	+0.4	VDDIO – +0.4
nINT/TXER/TXD4	0.63 * VDDIO	0.39 * VDDIO	-8 mA	+8 mA	+0.4	3.6

Table 7.6 LAN Interface Signals

NAME	V_{IH}	V_{IL}	I_{OH}	I_{OL}	V_{OL}	V_{OH}
TXP	See Table 7.11, "100Base-TX Transceiver Characteristics," on page 71 and Table 7.12, "10BASE-T Transceiver Characteristics," on page 72.					
TXN						
RXP						
RXN						

Table 7.7 LED Signals

NAME	V_{IH} (V)	V_{IL} (V)	I_{OH}	I_{OL}	V_{OL} (V)	V_{OH} (V)
LED1/REGOFF	$0.63 * VDD2A$	$0.39 * VDD2A$	-12 mA	+12 mA	+0.4	$VDD2A - +0.4$
LED2/nINTSEL	$0.63 * VDD2A$	$0.39 * VDD2A$	-12 mA	+12 mA	+0.4	$VDD2A - +0.4$

Table 7.8 Configuration Inputs

NAME	V_{IH} (V)	V_{IL} (V)	I_{OH}	I_{OL}	V_{OL} (V)	V_{OH} (V)
RXD0/MODE0	$0.63 * VDDIO$	$0.39 * VDDIO$	-8 mA	+8 mA	+0.4	$VDDIO - +0.4$
RXD1/MODE1	$0.63 * VDDIO$	$0.39 * VDDIO$	-8 mA	+8 mA	+0.4	$VDDIO - +0.4$
RXD2/RMIISEL	$0.63 * VDDIO$	$0.39 * VDDIO$	-8 mA	+8 mA	+0.4	$VDDIO - +0.4$
RXD3/PHYAD2	$0.63 * VDDIO$	$0.39 * VDDIO$	-8 mA	+8 mA	+0.4	$VDDIO - +0.4$
RXER/RXD4/PHYAD0	$0.63 * VDDIO$	$0.39 * VDDIO$	-8 mA	+8 mA	+0.4	$VDDIO - +0.4$
RXCLK/PHYAD1	$0.63 * VDDIO$	$0.39 * VDDIO$	-8 mA	+8 mA	+0.4	$VDDIO - +0.4$
COL/CRS_DV/MODE2	$0.63 * VDDIO$	$0.39 * VDDIO$	-8 mA	+8 mA	+0.4	$VDDIO - +0.4$

Table 7.9 General Signals

NAME	V_{IH} (V)	V_{IL} (V)	I_{OH}	I_{OL}	V_{OL} (V)	V_{OH} (V)
nINT/TXER/TXD4			-8 mA	+8 mA	+0.4	$VDDIO - +0.4$
nRST	$0.63 * VDDIO$	$0.39 * VDDIO$				
XTAL1/CLKIN (Note 7.3)	+1.40 V	$0.39 * VDD2A$				
XTAL2	-	-				

Note 7.3 These levels apply when a 0-3.3V Clock is driven into XTAL1/CLKIN and XTAL2 is floating. The maximum input voltage on XTAL1/CLKIN is $VDD2A + 0.4V$.



Table 7.10 Internal Pull-Up / Pull-Down Configurations

NAME	PULL-UP OR PULL-DOWN
nINT/TXER/TXD4	Pull-up
TXEN	Pull-down
RXD0/MODE0	Pull-up
RXD1/MODE1	Pull-up
RXD2/RMIISEL	Pull-down
RXD3/PHYAD2	Pull-down
RXER/RXD4/PHYAD0	Pull-down
RXCLK/PHYAD1	Pull-down
COL/CRS_DV/MODE2	Pull-up
CRS	Pull-down
LED1/REGOFF	Pull-down
LED2/nINTSEL	Pull-up
MDIO	Pull-up
nRST	Pull-up

Table 7.11 100Base-TX Transceiver Characteristics

PARAMETER	SYMBOL	MIN	TYP	MAX	UNITS	NOTES
Peak Differential Output Voltage High	V _{PPH}	950	-	1050	mVpk	Note 7.4
Peak Differential Output Voltage Low	V _{PPL}	-950	-	-1050	mVpk	Note 7.4
Signal Amplitude Symmetry	V _{SS}	98	-	102	%	Note 7.4
Signal Rise & Fall Time	T _{RF}	3.0	-	5.0	nS	Note 7.4
Rise & Fall Time Symmetry	T _{RFS}	-	-	0.5	nS	Note 7.4
Duty Cycle Distortion	D _{CD}	35	50	65	%	Note 7.5
Overshoot & Undershoot	V _{OS}	-	-	5	%	
Jitter				1.4	nS	Note 7.6

Note 7.4 Measured at the line side of the transformer, line replaced by 100Ω (± 1%) resistor.

Note 7.5 Offset from 16 nS pulse width at 50% of pulse peak

Note 7.6 Measured differentially.

Table 7.12 10BASE-T Transceiver Characteristics

PARAMETER	SYMBOL	MIN	TYP	MAX	UNITS	NOTES
Transmitter Peak Differential Output Voltage	V_{OUT}	2.2	2.5	2.8	V	Note 7.7
Receiver Differential Squelch Threshold	V_{DS}	300	420	585	mV	

Note 7.7 Min/max voltages guaranteed as measured with 100 Ω resistive load.

Chapter 8 Application Notes

8.1 Application Diagram

The LAN8710 requires few external components. The voltage on the magnetics center tap can range from 2.5 - 3.3V.

8.1.1 MII Diagram

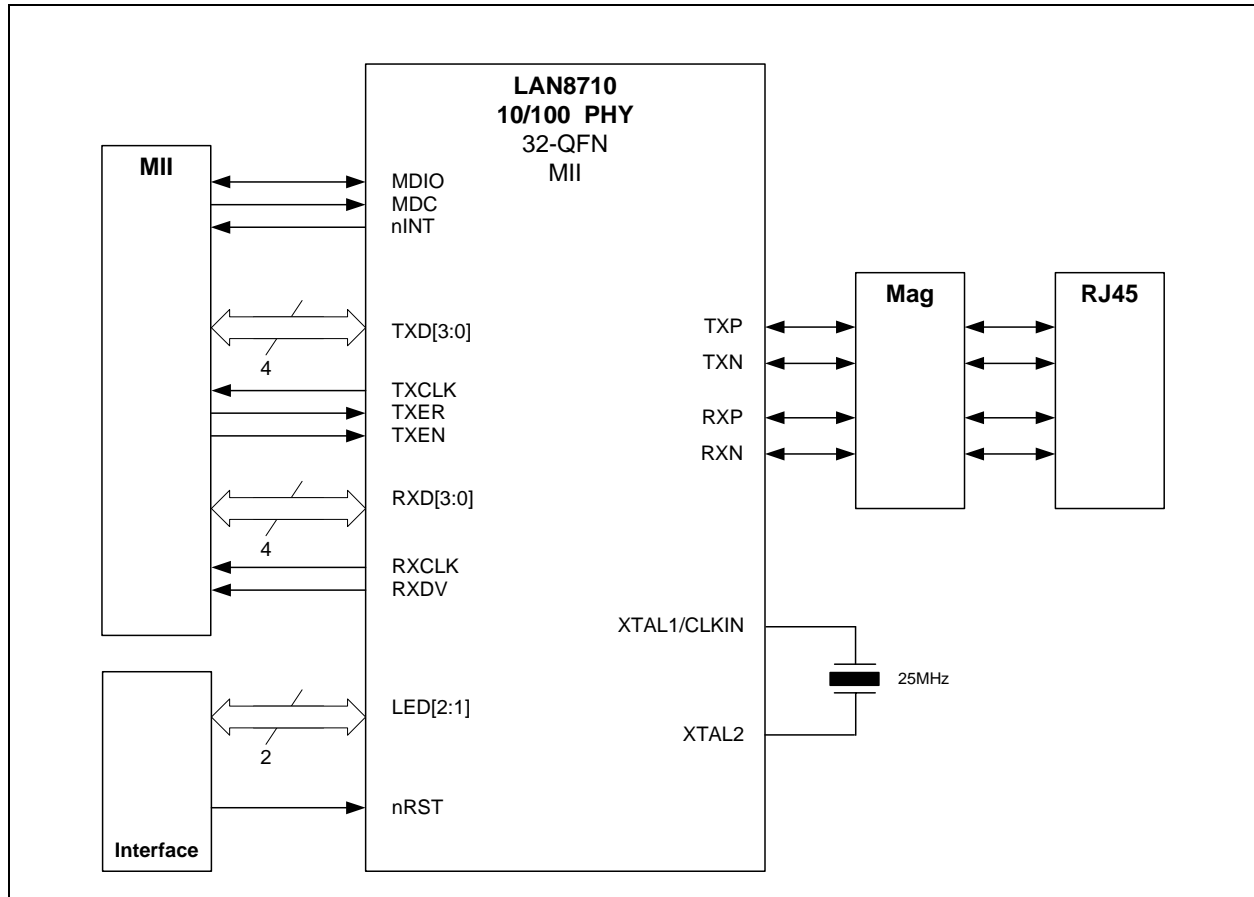

Figure 8.1 Simplified Application Diagram

8.1.2 Power Supply Diagram

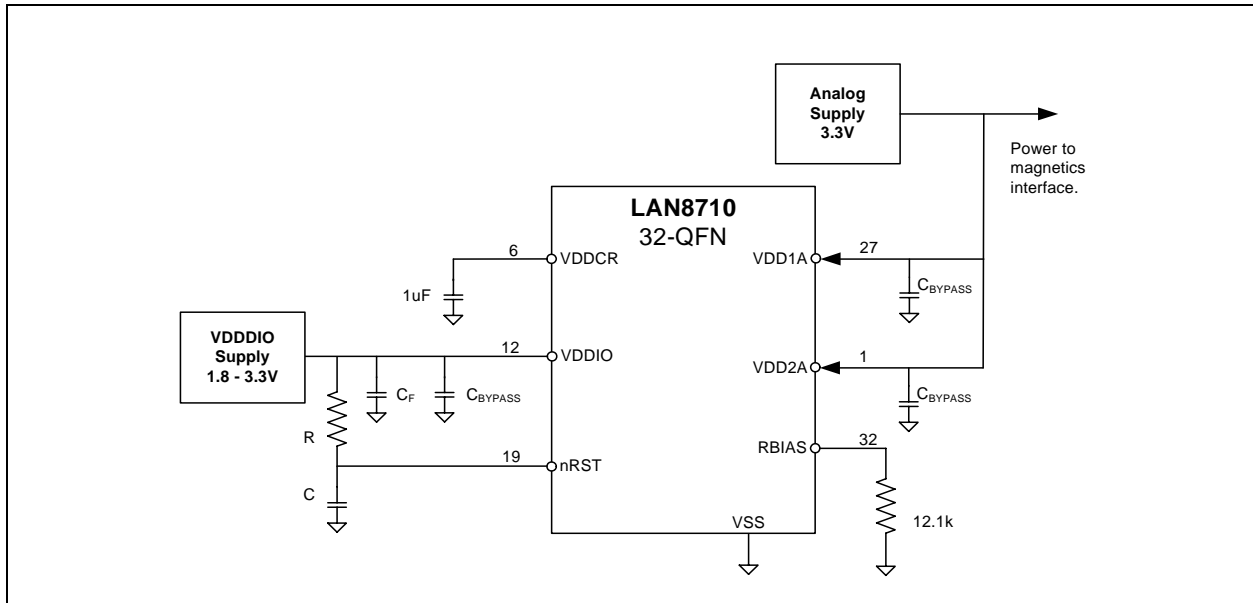

Figure 8.2 High-Level System Diagram for Power

8.1.3 Twisted-Pair Interface Diagram

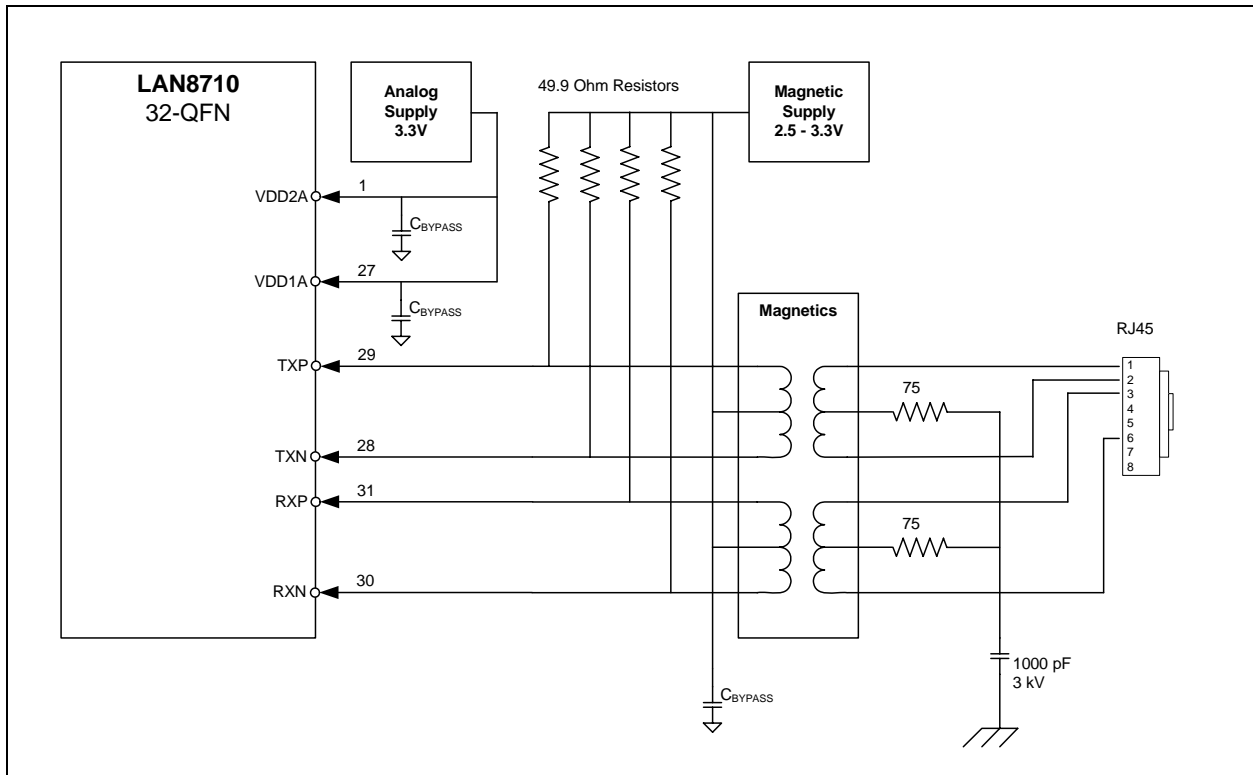

Figure 8.4 Copper Interface Diagram



Datasheet

8.2 Magnetics Selection

For a list of magnetics selected to operate with the SMSC LAN8710, please refer to the Application note "AN 8-13 Suggested Magnetics".

<http://www.smsc.com/main/appnotes.html#Ethernet%20Products>

Chapter 9 Package Outline

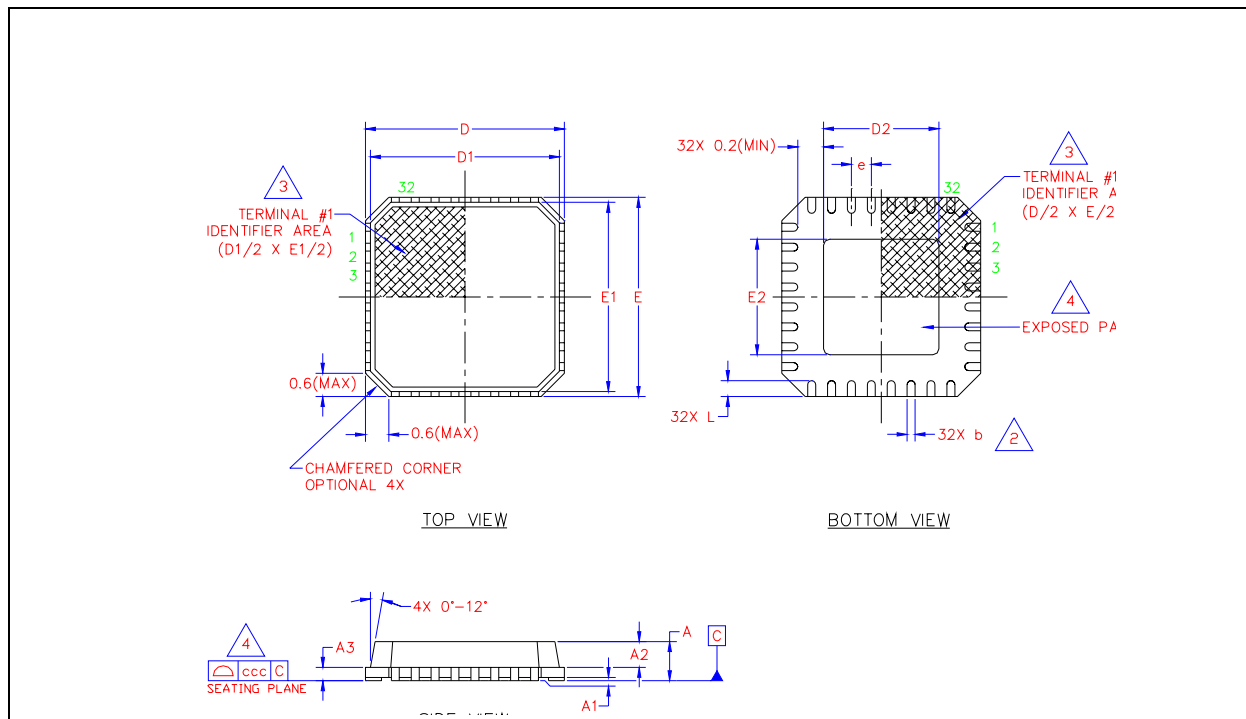

Figure 9.1 LAN8710/LAN8710i-EZK 32 Pin QFN Package Outline, 5 x 5 x 0.9 mm Body (Lead-Free)

Table 9.1 32 Terminal QFN Package Parameters

	MIN	NOMINAL	MAX	REMARKS
A	0.70	~	1.00	Overall Package Height
A1	0	0.02	0.05	Standoff
A2	~	~	0.90	Mold Thickness
A3	0.20 REF			Copper Lead-frame Substrate
D	4.85	5.0	5.15	X Overall Size
D1	4.55	~	4.95	X Mold Cap Size
D2	3.15	3.3	3.45	X exposed Pad Size
E	4.85	5.0	5.15	Y Overall Size
E1	4.55	~	4.95	Y Mold Cap Size
E2	3.15	3.3	3.45	Y exposed Pad Size
L	0.30	~	0.50	Terminal Length
e	0.50 BSC			Terminal Pitch
b	0.18	0.25	0.30	Terminal Width
ccc	~	~	0.08	Coplanarity

Notes:

1. Controlling Unit: millimeter.
2. Dimension b applies to plated terminals and is measured between 0.15mm and 0.30mm from the terminal tip. Tolerance on the true position of the leads is ± 0.05 mm at maximum material conditions (MMC).
3. Details of terminal #1 identifier are optional but must be located within the zone indicated.
4. Coplanarity zone applies to exposed pad and terminals.

Datasheet

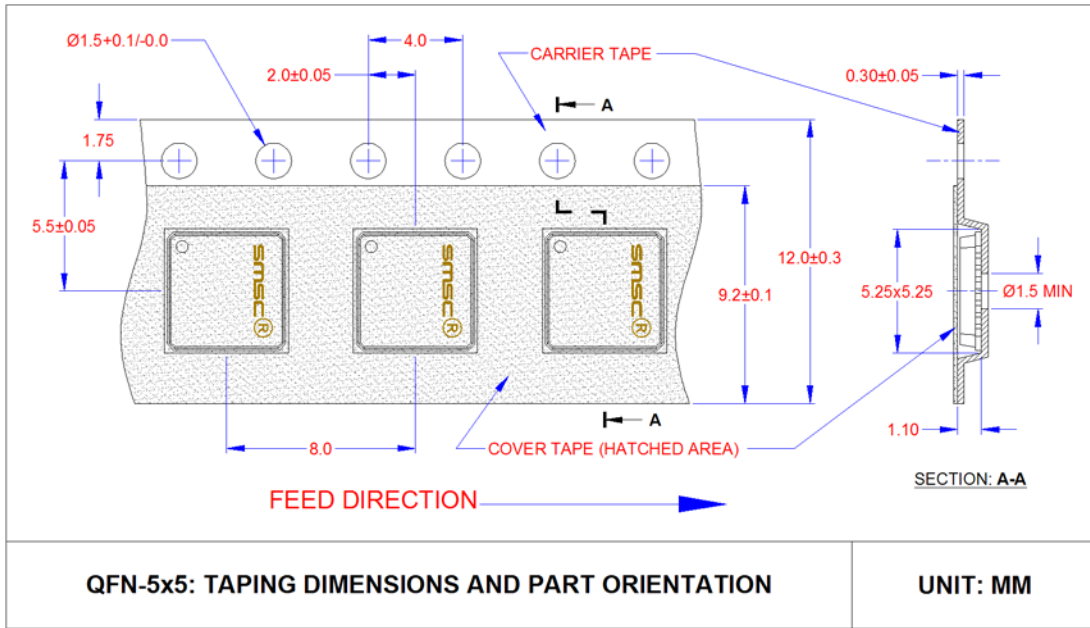

Figure 9.1 QFN, 5x5 Taping Dimensions and Part Orientation

REEL PHYSICAL DIMENSIONS

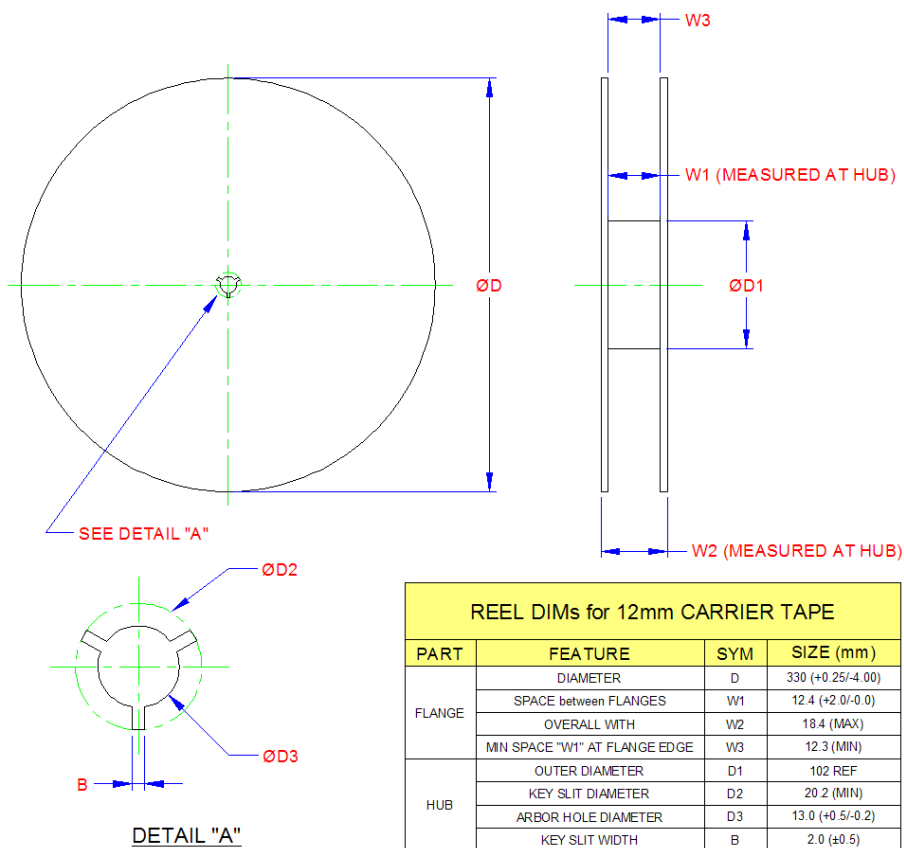
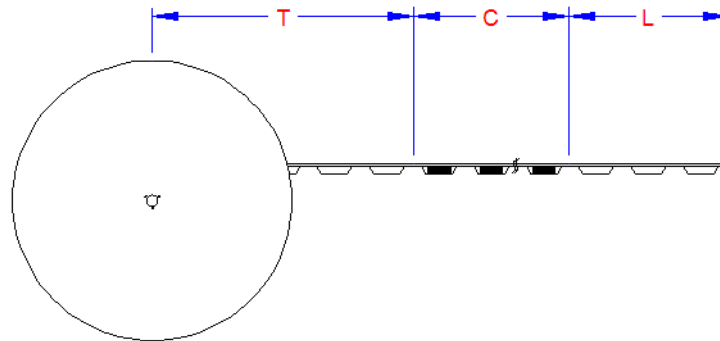

Figure 9.2 Reel Dimensions for 12mm Carrier Tape

TAPE LENGTH & PART QUANTITY



TAPE SECTIONS		
SECTION	SYM	SIZE
TRAILER	T	20 pockets (MN)
COMPONENT	C	4000 components
LEADER	L	50 pockets (MN)

Figure 9.3 Tape Length and Part Quantity

Note: Standard reel size is 4000 pieces per reel.